

**Hydraulic and Pneumatic Cylinders**  
Heavy-Duty Imperial Mill Type

Series EM

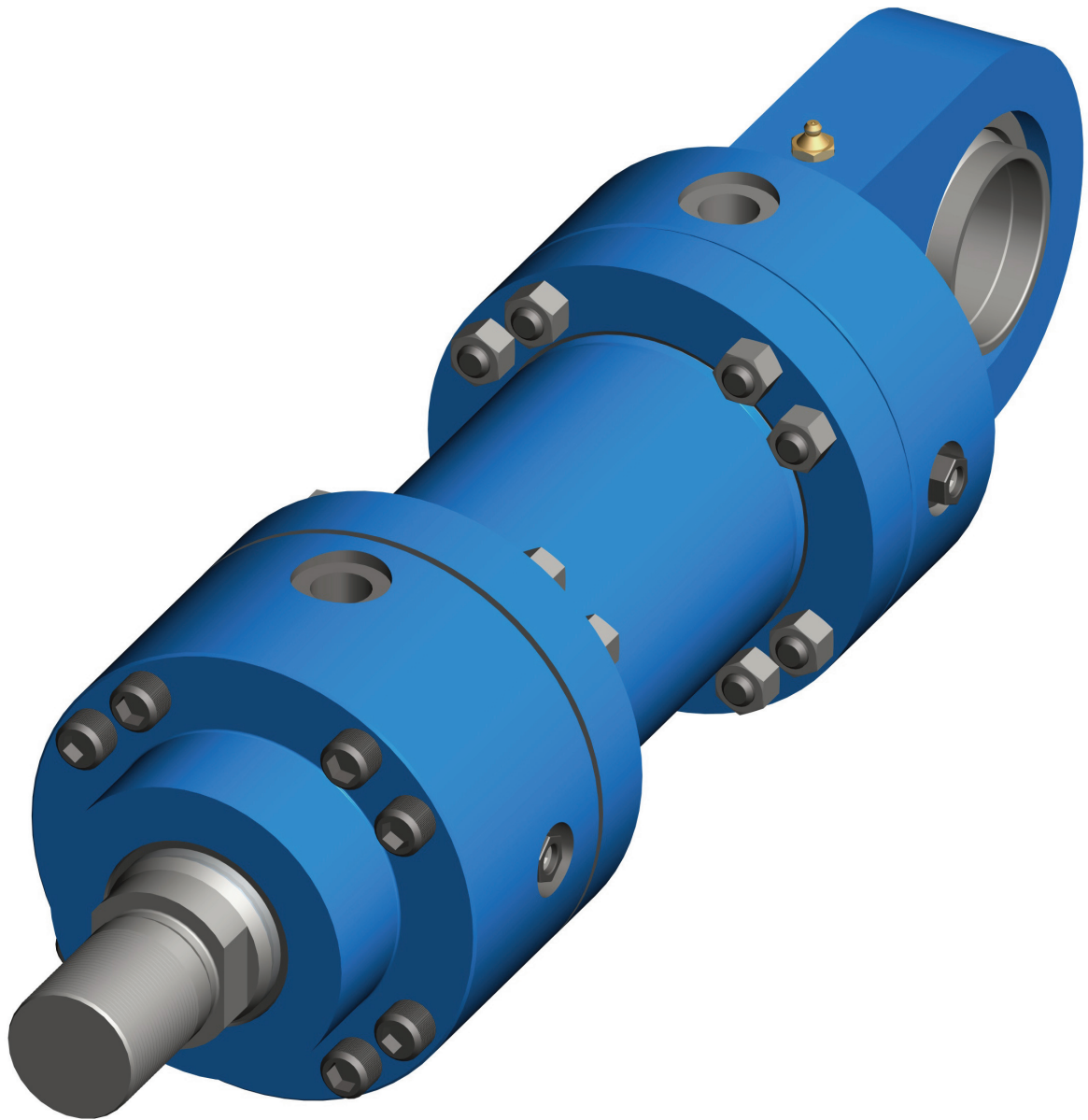

**EATON**

*Powering Business Worldwide*

# Table of Contents

<b>How to Order</b> .....	3
<b>Model Code</b> .....	4
<b>Mount Options</b> .....	6
<b>Design Features 2" to 8" Bore Sizes</b> .....	8
<b>Design Features 10" to 16" Bore Sizes</b> .....	9
<b>Mounting Style &amp; Installation Dimensions</b>	
AS Side Lug Foot Mounts .....	10
GS Head Rectangular Mount .....	12
CM Cap Clevis Mount .....	14
CS Spherical Bearing Mount .....	16
PS Cap Rectangular Mount .....	18
TS Intermediate Trunnion Mount .....	20
US Head Trunnion Mount .....	22
FS Head Circular Mount .....	23
KS No Mount .....	24
<b>Mounting Accessories</b> .....	26
<b>Common Options</b>	
Rod End Selection .....	29
Sealing Systems 2" to 8" Bore Sizes .....	30
Sealing Systems 10" to 16" Bore Sizes .....	31
Port and Cushion Selection .....	32
Seal Kits .....	34
Special Rod and Other Options .....	35
<b>Application/Engineering Data</b>	
Stop Tube .....	36
Proximity Switches .....	37
Transducer Options .....	38
Buckling Chart .....	39
Application Data Sheet .....	40

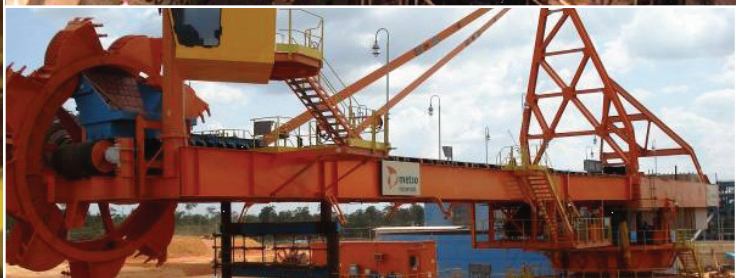
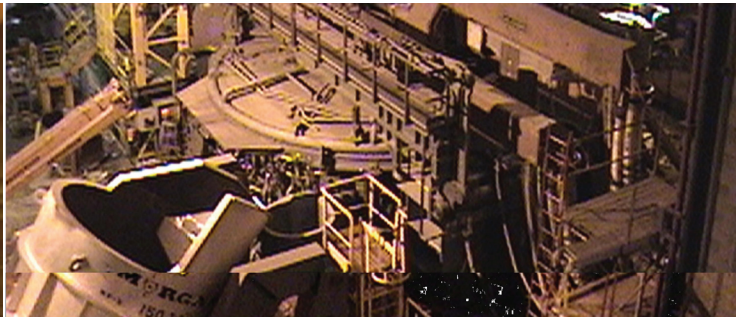

# How To Order

## Standard Cylinders

Eaton® has created an easy system for ordering Series EM Mill Cylinders. This system has been developed to improve our service to you. The model code consists of thirty alphanumeric digits which fully describe the most common standard options offered on the Series EM Mill Cylinders. To specify your Series EM cylinder, review the following pages for a full description of each option available and select the desired code. This model code system will:

### Simplify the re-order process

Each Eaton® cylinder is assigned a thirty six digit model code. That code is unique to a particular cylinder description. That way, when you re-order your Series EM Mill Cylinder, you're assured of exactly the same top quality cylinder design.

## Improve identification

Every cylinder has its thirty six digit model code clearly marked on the product. Each thirty six digit code completely describes a specific cylinder. This allows seals and replacement components to be easily identified in the field.

### Facilitate communications

This fully descriptive model code system allows you to work directly with your local Eaton® sales engineer to identify and service your Eaton® cylinder.

**Note:** See pages 4 and 5 for a summary of model code options.

## Custom Cylinders

### New Cylinders

Although the model code has been arranged to cover the vast majority of available options, there will be occasions when you require an option which cannot be coded. When specifying such an option, enter an "X" in the appropriate position in the model code or at the end of the model code, and then fully describe your requirements.

For example, if you have an application which requires a custom thread on the end of the piston rod, enter an "X" in position 26. Then add a full description at the end of the model code, such as "With 3.25 inch total rod projection and M22 x 1.5 thread 1.375 inches long." The cylinder will then be given a unique six digit design number on receipt of order (as explained in next section).

## Replacement Cylinders

For these cylinders, the model code is expanded to thirty-six digits. Each custom Eaton® cylinder is assigned a unique "Design Number". This number is the last six digits of the model code, starting in position 31. When ordering a replacement cylinder, simply give the thirty-six digit model code or the six digit design number to your local Eaton® Cylinder Sales representative.

### Replacement Parts

Each design number is stored in a quick retrieval computerized storage system. This gives our field sales representatives rapid access to assist you in identifying and specifying genuine Eaton® replacement parts

# Model Code

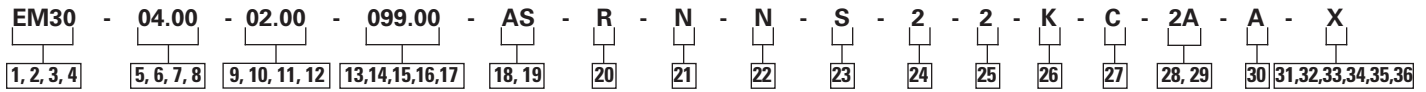

## 1, 2, 3, 4 Mill Cylinder Series

**EM30** - 3000 psi Hydraulic  
**EM20** - 2000 psi Hydraulic  
**EM02** - 250 psi Pneumatic

## 5, 6, 7, 8 Bore

Specify in inches (2 position decimal)

- 02.00** - 2" Dia. Bore
- 03.00** - 3" Dia. Bore
- 04.00** - 4" Dia. Bore
- 05.00** - 5" Dia. Bore
- 06.00** - 6" Dia. Bore
- 07.00** - 7" Dia. Bore
- 08.00** - 8" Dia. Bore
- 10.00** - 10" Dia. Bore
- 12.00** - 12" Dia. Bore
- 14.00** - 14" Dia. Bore
- 16.00** - 16" Dia. Bore

## 9, 10, 11, 12 Rod Diameter

Specify in inches (2 position decimal)

- 01.00** - 1" Rod Dia.
- 01.38** - 1.38" Rod Dia.
- 01.75** - 1.75" Rod Dia.
- 02.00** - 2" Rod Dia.
- 02.50** - 2.50" Rod Dia.
- 03.00** - 3" Rod Dia.
- 03.50** - 3.50" Rod Dia.
- 04.00** - 4.00" Rod Dia.
- 05.00** - 5" Rod Dia.
- 05.50** - 5.50" Rod Dia.
- 07.00** - 7" Rod Dia.
- 08.00** - 8" Rod Dia.
- 09.00** - 9" Rod Dia.
- 10.00** - 10" Rod Dia.

## 13, 14, 15, 16, 17 Stroke

Specify length in inches (3 positions to the left of decimal and 2 positions to the right). For example:

Code	Size
004.50	4.50
010.00	10
112.50	112.50 etc.

## 18, 19 Mounting Style

- AS** - Side Lug (Foot)
- GS** - Head Rectangular
- CM** - Cap Clevis Mount
- CS** - Spherical Bearing Mount
- PS** - Cap Rectangular Mount
- TS** - Intermediate Trunnion Mount
- US** - Head Trunnion Mount
- FS** - Head Circular Flange Mount
- KS** - No Mount
- AD** - Double Rod Side Lug
- GD** - Double Rod, Rectangular
- TD** - Double Rod, Intermediate Trunnion
- KD** - Double Rod, No Mount
- XX** - Custom

## 20 Cushion location

Cushion locations are viewing cylinder from head end (mounting end of double rod cylinders). "-" in table indicates no cushion.

Code	Head	Cap
A	-	-
B	-	1
C	-	2
D	-	3
E	-	4
F	1	-
G	2	-
H	3	-
J	4	-
K	1	1
L	1	2
M	1	3
N	1	4
P	2	1
R	2	2
S	2	3
T	2	4
U	3	1
V	3	2
W	3	3
Y	3	4
1	4	1
2	4	2
3	4	3
4	4	4

## Double Rod Cylinders:

"Head" = "Mounting End"

"Cap" = "Non Mounting End"

## 21, 22 Rod and Piston sealing system

- N-N** Normal
- L-N** Low friction
- T-T** High temperature
- N-H** Load holding

For complete sealing options please refer page no. 30 and 31

## 23 Port type and Size

- | Code     | Type           |
|----------|----------------|
| <b>N</b> | NPTF           |
| <b>P</b> | Oversized NPTF |

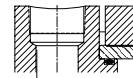

- |          |               |
|----------|---------------|
| <b>S</b> | SAE           |
| <b>U</b> | Oversized SAE |

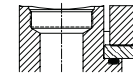

- |          |                   |
|----------|-------------------|
| <b>F</b> | SAE 4-Bolt Flange |
|----------|-------------------|

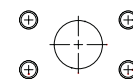

- |          |                |
|----------|----------------|
| <b>G</b> | BSPP           |
| <b>H</b> | Oversized BSPP |

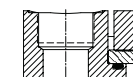

- |          |        |
|----------|--------|
| <b>X</b> | Custom |
|----------|--------|

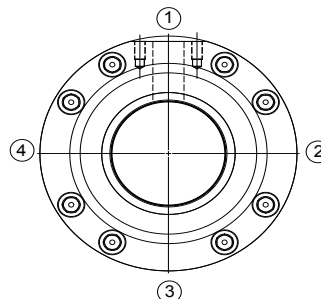

Cushion positions view from Rod end Side

# Model Code

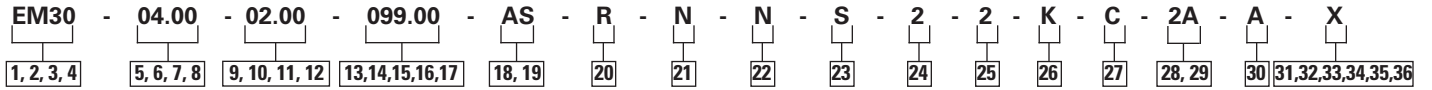

## 24 Head Port position

Code	1 <sup>st</sup> port	2 <sup>nd</sup> port
1	1	-
2	2	-
3	3	-
4	4	-
A	1	2
B	1	3
C	1	4
E	2	3
F	2	4
H	3	4

## 25 Cap Port position

Code	1 <sup>st</sup> port	2 <sup>nd</sup> port
1	1	-
2	2	-
3	3	-
4	4	-
5	5	-
A	1	2
B	1	3
C	1	4
D	1	5
E	2	3
F	2	4
G	2	5
H	3	4
J	3	5

Port positions view from Rod end Side

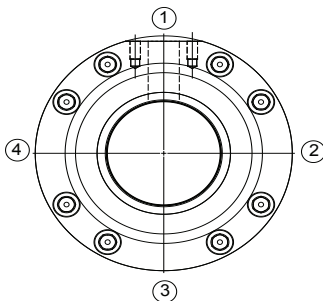

## 26 Rod End Types

Code	Type
4	Short female UN Thread 
2	Small Male UN Thread 
5	Plain no attachment 
1	Int. Male UN Thread 
G	Groove End 
K	Extended Small Male UNThd. 
M	Extended Int. Male UN Thread 
W	Male Thread (Rod Access.) 
X	Custom Rod End

## 27 Rod Material Option

- C** - Chrome Plate (Std option)
- E** - Heavy Chrome Plate (.002" per side)
- H** - Case Hardened (Rod Sizes 4 1/2" and larger")
- N** - Nickel Chrome Plate
- P** - Nitride Rod
- S** - 17-4 Stainless Steel

## 28, 29 Extra Rod Projection

Item 28 indicates inches from 0 thru 9. Item 29 indicates fraction of an inch per the following codes:

Code	Fraction
0	0
1	1/16
2	1/8
3	3/16
4	1/4
5	5/16
6	3/8
7	7/16
8	1/2
9	9/16
A	5/8
B	11/16
C	3/4
D	13/16
E	7/8
F	15/16

## 30 Design Level

- A** - First design

## 31-36 - Design Number

This is the Design Number field for custom cylinder designs.

## Custom Modifications:

For specifying special modifications place an X in this field. Special Options available, but not limited to are as follows:

- Air bleeds
- Rod boots
- Gland Drains
- Proximity Switches
- Stop tube
- Transducers
- Additional rod end flats
- Non-standard mount
- Port or cushions modifications
- Double-end rod with different rod ends
- Bronze bushings
- Special paint/plating

# Mount Options

## Side Lug Mount (Codes AS, AD)

Side Lug Mounts are for moving loads along a flat guided surface, as in a carriage along rails. The mounting surface should be flat and parallel to the center line of the piston rod.

The load should be guided to traverse along the center line of the piston rod. With unsupported loads, the bearing must absorb more force. For these applications, the larger alternate rod is recommended and stop tubes should be considered.

### NOTE

For strokes in excess of 30 inches, see "Stop tube selection" on page 35. The frame on which the cylinder is mounted must be sufficiently rigid to resist bending moments. Use high tensile socket head cap screws or hex head bolts tightened to the manufacturer's recommended torque. For high shock applications, dowel pins or shear keys should be incorporated in the mounting design. For severe side load applications, consult your local Eaton sales engineer.

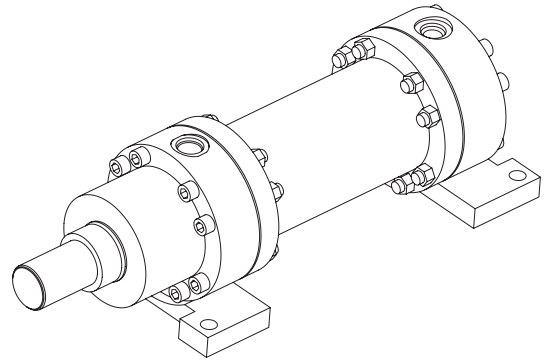

## Head/Cap Rectangular Mount (Codes GS, PS, GD)

These mounts are ideal for straight line force transfer applications in which the cylinder is used in tension pulling) as in pull presses. For compression applications (pushing), a Cap Rectangular is more appropriate.

The mounting surface should be flat and the Head bearing should be piloted into it. The force of the load should be perpendicular to the mounting surface and parallel the center line of the piston rod. For eccentric loads, the oversize alternate rod is recommended and stop tubes should be considered.

### NOTE

For strokes in excess of 30 inches, see "Stop tube selection" on page 35. The frame on which the cylinder is mounted must be sufficiently rigid to resist bending moments. Use high tensile socket head cap screws or hex head bolts tightened to the manufacturer's recommended torque.

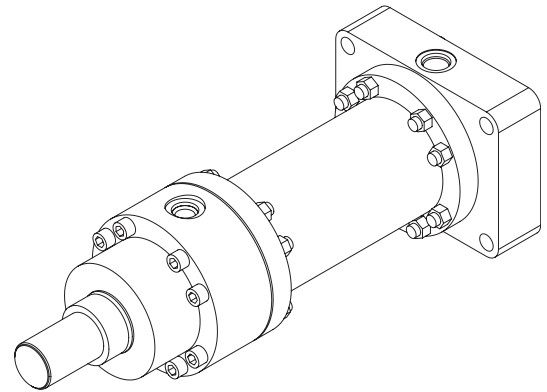
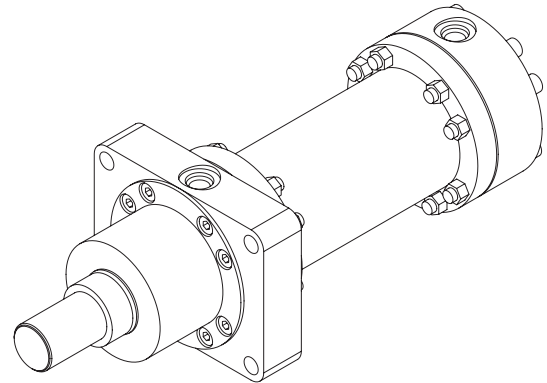

## Clevis Mount (Code CM)

This mount is for applications in which the machine member travels in a curved path within one plane. This mount can be used both in compression (push) and tension (pull).

### NOTE

For strokes in excess of 30 inches, see "Stop tube selection" on page 35. Care must be exercised to prevent rod buckling in compression applications with long strokes. See page 38 for stroke limitations.

The center line of the machine member that attaches to the swivel pin must be perpendicular to the center-line of the piston rod and the curved path must be in one plane only. Any misalignment will cause excess side loading on the bearing and piston. This will lead to premature failure.

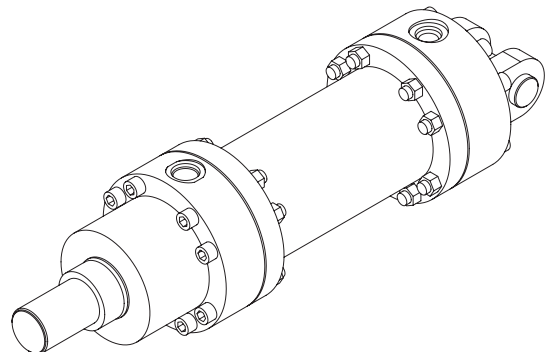

# Mount Options

## Spherical Bearing Mount (Code CS)

This mount is for applications in which the machine member travels in a curved path in one plane where some misalignment is unavoidable. The amount of allowable misalignment can be calculated. This mount can be used both in compression (push) and tension (pull) applications. Care must be exercised to prevent rod buckling in compression applications with long strokes.

### NOTE

For strokes in excess of 24 inches, see "Stop tube selection" on page 35.

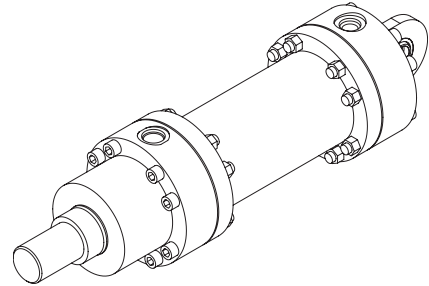

## Head Circular Flange Mount (Code FS)

These mounts are ideal for straight line force transfer applications in which the cylinder is used in tension (pulling). The mounting surface should be flat, and the rod end should be piloted into it. The frame on which the cylinder is mounted must be sufficiently rigid to resist bending moments.

### NOTE

For strokes in excess of 30 inches, see "Stop tube selection" on page 35. The force of the load should be perpendicular to the mounting surface and parallel to the center line of the piston rod. For eccentric loads, the larger of the two available rods in each bore size is recommended. Stop tubes should also be considered. The head rectangular mount is recommended for heavy duty applications. Use high tensile socket head cap screws or hex head bolts tightened to the manufacturer's recommended torque.

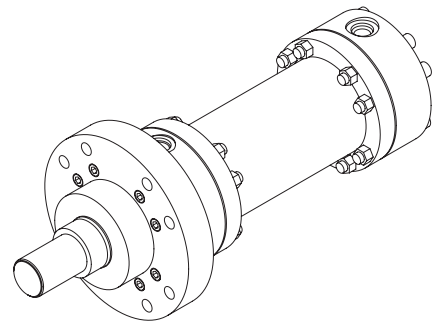

## Intermediate Trunnion (Code TS)

The Intermediate Trunnion Mount is for longer stroke applications in which the machine member travels in a curved path in one plane. On special orders, the trunnion can be located anywhere along the body. This mount can be used both in compression (push) and tension (pull) applications.

### NOTE

For strokes in excess of 24 inches, see "Stop tube selection" on page 35. It is recommended that rigidly mounted pillow blocks with bearings at least as long as the trunnion pins be used. The pillow blocks should be installed as close to the shoulder of the trunnion as possible.

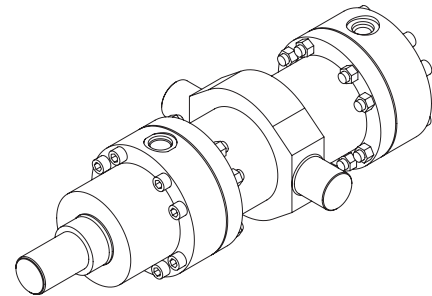

## Head Trunnion (Code US)

These mounts are for applications in which the machine member travels in a curved path within one plane. Either mount can be used both in compression (push) and tension (pull) applications. Head Trunnion Mounts provide a longer maximum stroke than Cap Trunnion Mounts, when used in compression.

### NOTE

For strokes in excess of 30 inches, see "Stop tube selection" on page 35. The trunnion pins are an integral part of the head and can be sleeved to provide an extremely tight fit to the mating machine member and permit curvilinear motion. It is recommended that rigidly mounted pillow blocks with bearings at least as long as the trunnion pins be used and be installed as close to the shoulder of the trunnion as possible.

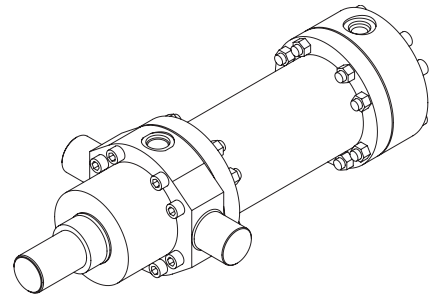

## Double Rod Cylinders (Mount Codes KD, AD, GD, TD)

Double end cylinders are specified when equal displacement is desired on both sides of the piston or when the application is such that another function can be performed simultaneously with a second rod. The single rod mount application data is applicable for all double Head cylinders.

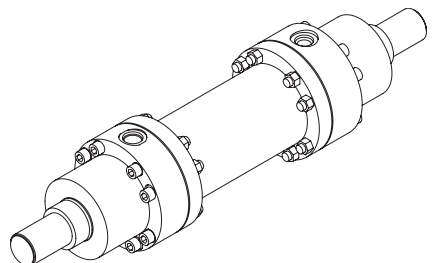

# Design Features

## Up to 8" Bore Sizes

### Specifications

Bore Sizes: 2" - 8"

Piston Rod Dia.: 1" - 5.5"

### Pressure Ratings:

EM02 - 250 psi Pneumatic Service

EM20 - 2,000 psi Nominal Hydraulic Service

EM30 - 3,000 psi Nominal Hydraulic Service

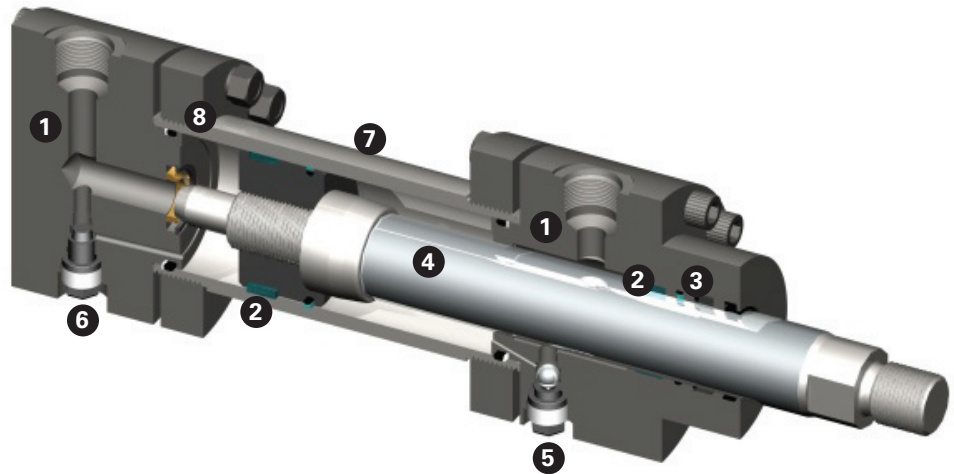

### 1. Head & Caps

One Piece round construction head and caps are manufactured from high strength material with precise machining to ensure accurate alignment with the cylinder bore.

An integral bearing and seal design featuring heavy duty polymer wear bands resists side loads. The wide separation of these wear bands reduce bearing stresses, and maximize cylinder service.

Optional rod cartridge with SAE 660 bronze, aluminum bronze material or wearbands allows for easy seal and bearing replacement without dis-assembly of whole cylinder. These can be ordered as custom options.

### 2. Special Wearbands

Metal-to-metal contact is eliminated, providing superior wearability, increased load carrying capability, and prolonged cylinder life.

### 3. Sure Seal Sealing System

Carefully selected wiper and seal combinations are mated with a hard chrome plated piston rod to deliver exceptional all-around performance and durability. Hydraulic cylinders use a high durometer urethane "ultra seal" double lip rod seal along with an O-ring energized slide ring and a double lip rod wiper to provide positive static and dynamic sealing at low and high pressures. Pneumatic cylinders use a high quality nitrile U-cup rod seal and double-lipped wiper.

This system offers not only a selection of highly efficient piston seal materials, but also an extra wide wearband that rides smoothly within the precision-honed cylinder body to provide extended piston seal life.

The use of bi-directional piston seals eliminates trapped pressures. Extra Heavy Duty Capped T design as well as other rod sealing and wiping systems are available as options.

### 4. High Yield Piston Rod

Hard chrome plated piston rod in a variety of diameters between 1 and 5 1/2 inches provides maximum durability and extends seal life. Case hardened rods are standard up to 4 inches, and are an option for 4 1/2 inch and larger rods. Several different rod end types are available. Heavier plating is available as an option, in addition to various types of stainless steel and chrome over nickel plated rod material.

### 5. Captive Screws

Inadvertent removal of cushion screws is prevented, while still allowing a full range of adjustment.

### 6. Fully Adjustable Cushioning System

This design has been engineered to provide the ability to tune the cushion performance for an optimized deceleration profile. Our patented floating ring cushion seal or an alternate ball check design allows maximum acceleration. This excellent acceleration profile translates into faster cycle times and increased machine production.

### 7. High Yield Steel Tubing

High yield strength steel is used to insure long cylinder life. Pneumatic cylinders use tubes that are honed & chrome-plated to a minimum of .0006" diametrically.

Plating of bores for Hydraulic cylinders and heavier plating on pneumatic bores are available as options.

### 8. Threaded Body Flanges

The threaded steel flange design has superior bending stress capacity, durability, and increased safety factors of shear over similar welded flange type designs.

High strength bolts (per ASTM A574) are used for assembly with hardened steel washers to guarantee failure free performance.



# Design Features

## 10" and Above Bore Sizes

### Specifications

Bore Sizes: 10" - 16"

Piston Rod Dia.: 4" - 10"

### Pressure Ratings:

EM02 - 250 psi Pneumatic Service

EM20 - 2,000 psi Nominal Hydraulic Service

EM30 - 3,000 psi Nominal Hydraulic Service

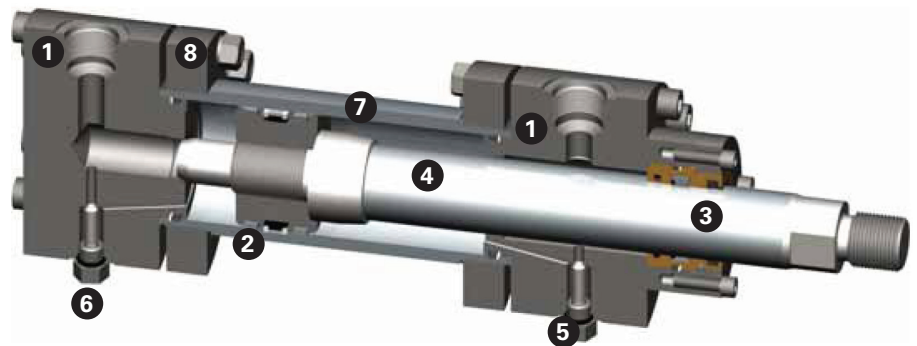

### 1. Head & Caps

SAE 660 bronze rod cartridge is pilot-fitted into the head and incorporates inboard and outboard bearing areas to give maximum bearing support and wear resistance.

Unitized, threadless assembly is pilot-fitted into the head on a precision bored diameter to assure true concentricity.

Cartridge design allows for easy seal and bearing replacement without disassembly of whole cylinder.

One piece head with wearbands available as custom option.

### 2. Piston Wearbands

Metal-to-metal contact is eliminated, providing superior wearability, increased load carrying capability, and prolonged cylinder life.

### 3. Sure Seal Sealing System

Carefully selected wiper and seal combinations are mated with a hard chrome plated piston rod to deliver exceptional all-around performance and durability. Hydraulic cylinders use a high durometer urethane mechanically loaded rod seal along with an O-ring energized slide ring and a double lip rod wiper to provide positive static and dynamic sealing at low and high pressures. Pneumatic cylinders use a high quality nitrile U-cup rod seal and double-lipped wiper.

This system offers not only a selection of highly efficient piston seal materials, but also an extra wide wearband that rides smoothly within the precision-honed cylinder body to provide extended piston seal life.

The use of bi-directional piston seals eliminates trapped pressures. Extra Heavy Duty Capped T design available as well as other rod sealing and wiping systems are available as options.

### 4. High Yield Piston Rod

Hard chrome plated piston rod in a variety of diameters between 4" and 10" provides maximum durability and extends seal life. Several different rod end types are available.

Heavier plating is available as an option, in addition to various types of stainless steel and chrome over nickel plated rod material.

### 5. Captive Screws

Inadvertent removal of cushion screws is prevented, while still allowing a full range of adjustment.

### 6. Fully Adjustable Cushioning System

This design has been engineered to provide the ability to tune the cushion performance for an optimized deceleration profile. Our patented floating ring cushion seal or an alternate ball check design allows maximum acceleration. This excellent acceleration profile translates into faster cycle times and increased machine production.

### 7. High Yield Steel Tubing

High yield strength steel is used to insure long cylinder life. Pneumatic cylinders use tubes that are honed & chrome-plated to a minimum of .0006" diametrically.

Plating of bores for Hydraulic cylinders and heavier plating on pneumatic bores are available as options.

### 8. Welded Body Flanges

High strength bolts (per ASTM A574) and body flanges are assembled with hardened steel washers to guarantee failure free performance.

# Mounting Style and Installation Dimensions

## AS Side Lug (Foot) Mount

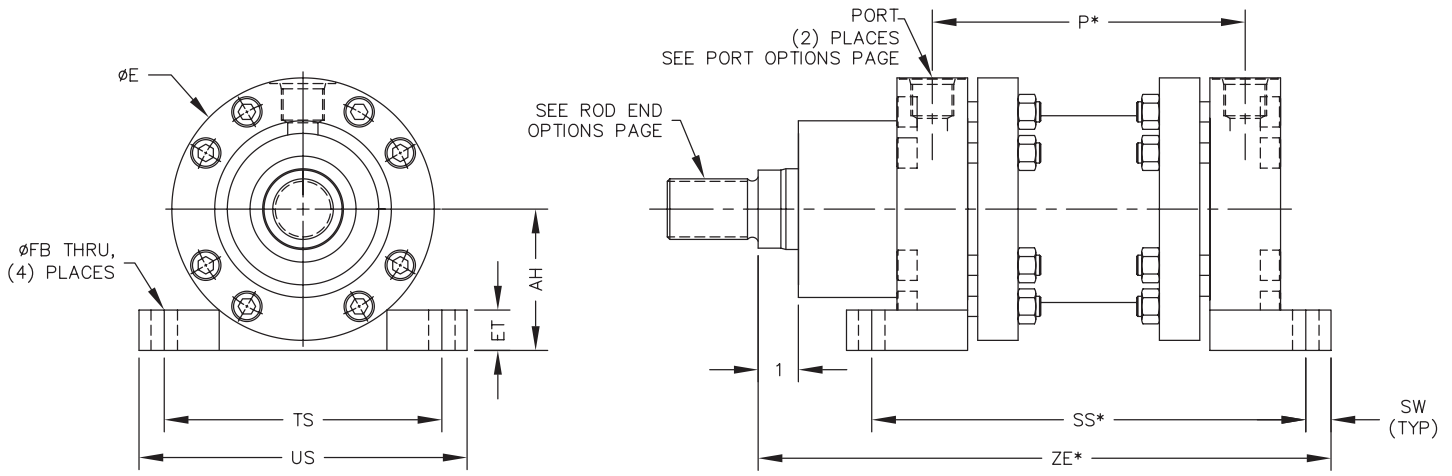

### EM20-AS (2000 Psi) / EM02-AS (250 Psi)

Bore	Rods	E	P*	ZE*	SS*	SW	FB	US	TS	ET	AH
2.00	1.00	3.88	3.75	8.13	6.13	0.38	0.41	5.06	4.25	0.63	2.188
	1.38	3.88	3.75	8.13	6.13	0.38	0.41	5.06	4.25	0.63	2.188
3.00	1.38	5.19	4.25	9.63	7.00	0.50	0.56	6.56	5.56	0.75	2.844
	2.00	5.19	4.25	9.63	7.00	0.50	0.56	6.56	5.56	0.75	2.844
4.00	1.75	6.25	4.50	10.88	7.50	0.63	0.69	7.88	6.63	1.00	3.375
	2.50	6.25	4.50	10.88	7.50	0.63	0.69	7.88	6.63	1.00	3.375
5.00	2.00	7.88	5.50	13.13	9.25	0.75	0.81	9.75	8.25	1.13	4.188
	3.50	7.88	5.50	13.13	9.25	0.75	0.81	9.75	8.25	1.13	4.188
6.00	2.50	9.25	6.25	14.88	10.88	1.00	1.06	11.63	9.63	1.50	4.875
	4.00	9.25	6.25	14.88	10.88	1.00	1.06	11.63	9.63	1.50	4.875
7.00	3.00	10.75	6.38	15.88	11.25	1.13	1.19	13.25	11.13	1.75	5.625
	5.00	10.75	6.38	15.88	11.25	1.13	1.19	13.25	11.13	1.75	5.625
8.00	3.50	12.00	7.75	18.13	13.75	1.25	1.31	14.88	12.38	1.88	6.250
	5.50	12.00	7.75	18.13	13.75	1.25	1.31	14.88	12.38	1.88	6.250

### EM30-AS (3000 Psi)

Bore	Rods	E	P*	ZE*	SS*	SW	FB	US	TS	ET	AH
3.00	1.75	5.19	4.50	10.63	7.25	0.50	0.56	6.56	5.56	0.75	2.844
	2.00	5.19	4.50	10.63	7.25	0.50	0.56	6.56	5.56	0.75	2.844
4.00	2.00	6.25	4.75	11.19	7.75	0.63	0.69	8.13	6.88	1.00	3.500
	2.50	6.25	4.75	11.19	7.75	0.63	0.69	8.13	6.88	1.00	3.500
5.00	2.50	7.88	5.75	14.00	9.50	0.75	0.81	9.75	8.25	1.13	4.188
	3.50	7.88	5.75	14.00	9.50	0.75	0.81	9.75	8.25	1.13	4.188
6.00	3.00	9.25	6.50	16.13	11.13	1.00	1.06	11.63	9.63	1.50	4.875
	4.00	9.25	6.50	16.13	11.13	1.00	1.06	11.63	9.63	1.50	4.875
7.00	3.50	10.75	7.12	18.13	12.00	1.13	1.19	13.38	11.13	1.56	5.625
	5.00	10.75	7.12	18.13	12.00	1.13	1.19	13.38	11.13	1.56	5.625
8.00	4.00	12.25	8.50	20.94	14.50	1.25	1.31	15.38	12.75	1.88	6.438
	5.50	12.25	8.50	20.94	14.50	1.25	1.31	15.38	12.75	1.88	6.438

All dimensions are in inches.

\* Add stroke to these dimensions.

# Mounting Style and Installation Dimensions

## AS Side Lug (Foot) Mount

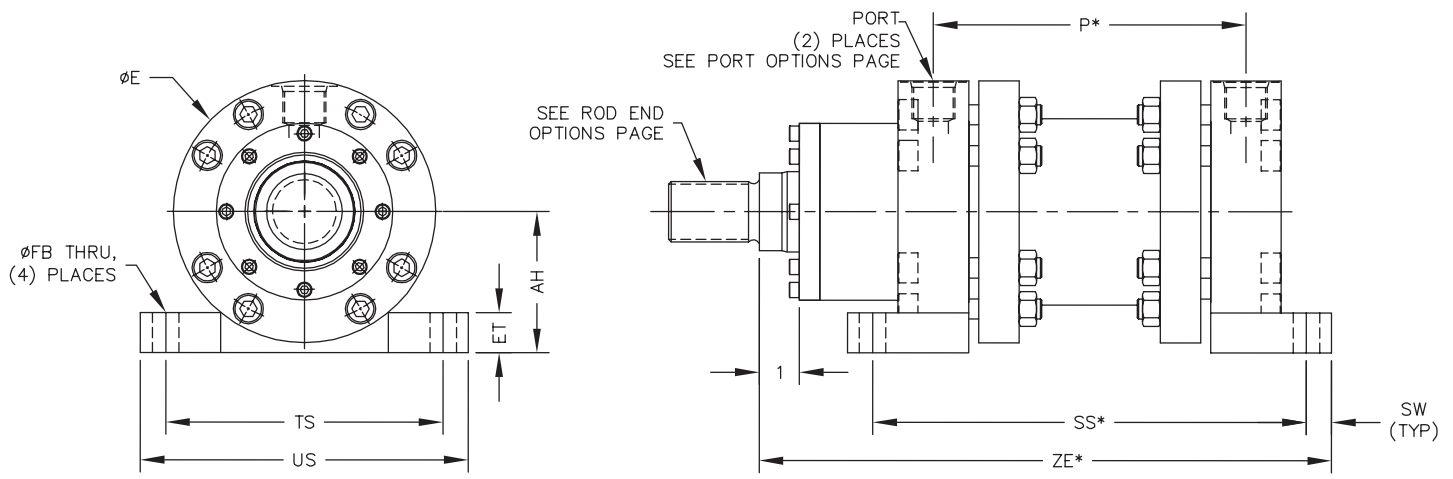

### EM20-AS (2000 Psi) / EM02-AS (250 Psi)

Bore	Rods	E	P*	ZE*	SS*	SW	FB	US	TS	ET	AH
10.00	4.00	14.94	9.25	20.44	15.75	1.50	1.56	18.31	15.31	2.25	7.781
	5.50	14.94	9.25	20.44	15.75	1.50	1.56	18.31	15.31	2.25	7.781
12.00	5.50	17.19	10.44	23.25	17.75	1.75	1.81	21.06	17.56	2.63	9.125
	7.00	17.19	10.44	23.25	17.75	1.75	1.81	21.06	17.56	2.63	9.125
14.00	7.00	19.50	10.69	25.25	18.50	2.00	2.06	23.88	19.88	3.00	10.500
	9.00	19.50	10.69	25.25	18.50	2.00	2.06	23.88	19.88	3.00	10.500
16.00	9.00	23.38	11.19	28.38	20.38	2.25	2.31	28.25	23.75	3.38	12.438
	10.00	23.38	11.19	28.38	20.38	2.25	2.31	28.25	23.75	3.38	12.438

### EM30-AS (3000 Psi)

Bore	Rods	E	P*	ZE*	SS*	SW	FB	US	TS	ET	AH
10.00	5.00	14.94	10.50	25.44	17.00	1.50	1.56	18.31	15.31	2.25	7.781
	7.00	14.94	10.50	25.44	17.00	1.50	1.56	18.31	15.31	2.25	7.781
12.00	5.50	17.50	11.31	27.88	18.63	1.75	2.06	21.63	17.88	2.63	9.125
	8.00	17.50	11.31	27.88	18.63	1.75	2.06	21.63	17.88	2.63	9.125
14.00	7.00	20.38	11.56	29.75	19.38	2.00	2.06	24.75	20.75	3.00	10.688
	9.00	20.38	11.56	29.75	19.38	2.00	2.06	24.75	20.75	3.00	10.688
16	9.00	23.38	12.50	33.75	21.25	2.25	2.31	28.25	23.75	3.38	12.438
	10.00	23.38	12.50	33.75	21.25	2.25	2.31	28.25	23.75	3.38	12.438

All dimensions are in inches.

\* Add stroke to these dimensions.

# Mounting Style and Installation Dimensions

## GS Head Rectangular Mount

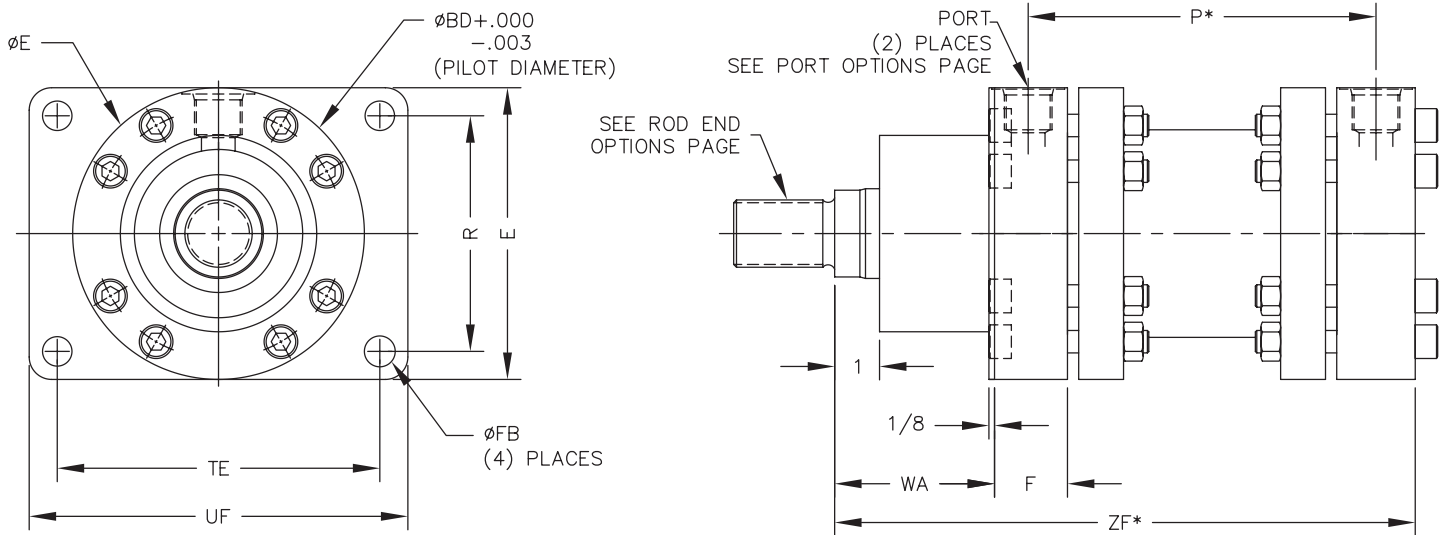

### EM20-GS (2000 Psi) / EM02-GS (250 Psi)

Bore	Rods	E	P*	ZF*	F	FB	R	TE	UF	BD	WA
2.00	1.00	3.88	3.75	7.38	1.50	0.41	3.13	4.25	5.00	3.875	2.19
	1.38	3.88	3.75	7.38	1.50	0.41	3.13	4.25	5.00	3.875	2.19
3.00	1.38	5.19	4.25	8.63	1.63	0.56	4.19	5.75	6.75	5.188	2.63
	2.00	5.19	4.25	8.63	1.63	0.56	4.19	5.75	6.75	5.188	2.63
4.00	1.75	6.25	4.50	9.63	1.63	0.69	5.00	6.94	8.19	6.250	3.50
	2.50	6.25	4.50	9.63	1.63	0.69	5.00	6.94	8.19	6.250	3.50
5.00	2.00	7.88	5.50	11.63	2.13	0.81	6.38	8.69	10.19	7.875	3.88
	3.50	7.88	5.50	11.63	2.13	0.81	6.38	8.69	10.19	7.875	3.88
6.00	2.50	9.25	6.25	12.88	2.50	1.06	7.25	10.31	12.31	9.250	4.00
	4.00	9.25	6.25	12.88	2.50	1.06	7.25	10.31	12.31	9.250	4.00
7.00	3.00	10.75	6.38	13.63	2.50	1.19	8.38	11.94	14.19	10.750	4.63
	5.00	10.75	6.38	13.63	2.50	1.19	8.38	11.94	14.19	10.750	4.63
8.00	3.50	12.00	7.75	15.63	3.38	1.31	9.50	13.31	15.81	12.000	4.38
	5.50	12.00	7.75	15.63	3.38	1.31	9.50	13.31	15.81	12.000	4.38

### EM30-GS (3000 Psi)

Bore	Rods	E	P*	ZF*	F	FB	R	TE	UF	BD	WA
3.00	1.75	5.19	4.50	9.63	1.63	0.56	4.19	5.75	6.75	5.187	3.50
	2.00	5.19	4.50	9.63	1.63	0.56	4.19	5.75	6.75	5.187	3.50
4.00	2.00	6.50	4.75	9.94	1.63	0.69	5.25	7.19	8.44	6.498	3.56
	2.50	6.50	4.75	9.94	1.63	0.69	5.25	7.19	8.44	6.498	3.56
5.00	2.50	7.88	5.75	12.50	2.13	0.81	6.38	8.69	10.19	7.875	4.63
	3.50	7.88	5.75	12.50	2.13	0.81	6.38	8.69	10.19	7.875	4.63
6.00	3.00	9.25	6.50	14.13	2.50	1.06	7.25	10.31	12.25	9.250	5.13
	4.00	9.25	6.50	14.13	2.50	1.06	7.25	10.31	12.25	9.250	5.13
7.00	3.50	10.75	7.12	15.88	2.50	1.19	8.50	11.94	14.19	10.750	6.25
	5.00	10.75	7.12	15.88	2.50	1.19	8.50	11.94	14.19	10.750	6.25
8.00	4.00	12.00	8.50	18.44	3.38	1.31	9.88	13.69	16.19	12.375	6.56
	5.50	12.00	8.50	18.44	3.38	1.31	9.88	13.69	16.19	12.375	6.56

All dimensions are in inches.

\* Add stroke to these dimensions.

# Mounting Style and Installation Dimensions

## GS Head Rectangular Mount

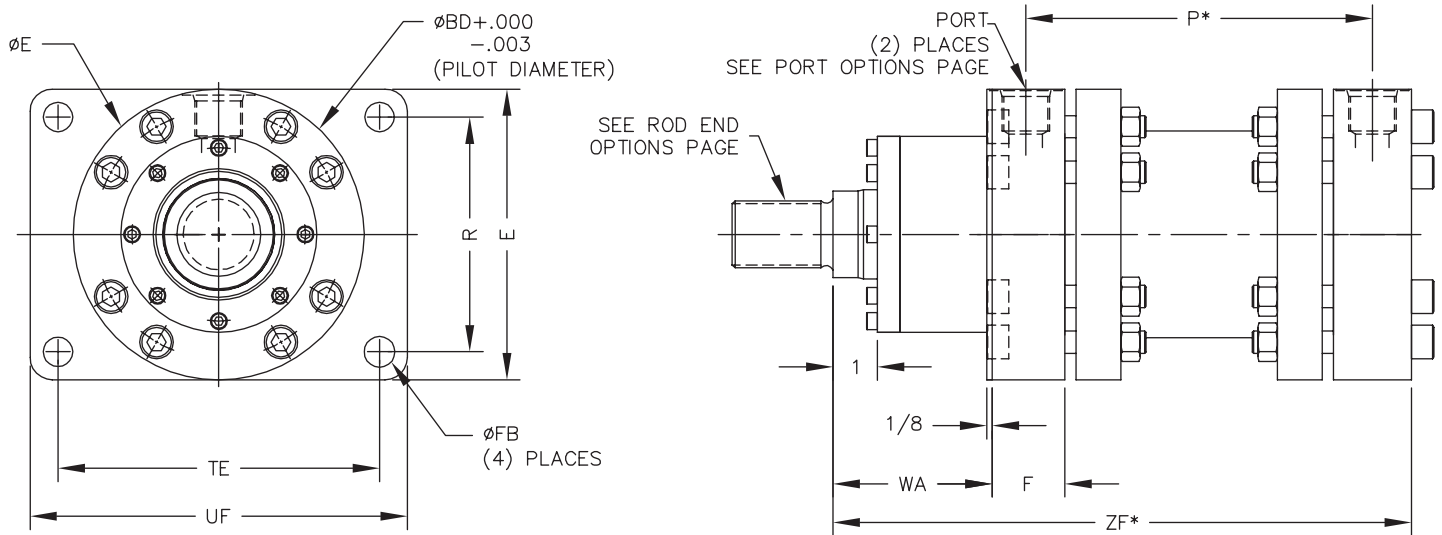

### EM20-GS (2000 Psi) / EM02-GS (250 Psi)

Bore	Rods	E	P*	ZF*	F	FB	R	TE	UF	BD	WA
10.00	4.00	14.94	9.25	17.44	3.38	1.56	11.94	16.50	19.50	14.937	4.81
	5.50	14.94	9.25	17.44	3.38	1.56	11.94	16.50	19.50	14.937	4.81
12.00	5.50	17.19	10.44	19.75	3.69	1.81	13.69	19.00	22.50	17.187	5.63
	7.00	17.19	10.44	19.75	3.69	1.81	13.69	19.00	22.50	17.187	5.63
14.00	7.00	19.50	10.69	21.50	3.69	2.06	15.50	21.56	25.56	19.500	7.13
	9.00	19.50	10.69	21.50	3.69	2.06	15.50	21.56	25.56	19.500	7.13
16.00	9.00	23.38	11.19	23.88	4.13	2.31	18.88	25.69	30.19	23.375	8.13
	10.00	23.38	11.19	23.88	4.13	2.31	18.88	25.69	30.19	23.375	8.13

### EM30-GS (3000 Psi)

Bore	Rods	E	P*	ZF*	F	FB	R	TE	UF	BD	WA
10.00	5.00	14.94	10.50	21.44	3.38	1.56	11.94	16.50	19.50	14.937	8.56
	7.00	14.94	10.50	21.44	3.38	1.56	11.94	16.50	19.50	14.937	8.56
12.00	5.5	17.50	11.31	24.38	3.69	1.81	14.00	19.31	22.81	17.50	9.38
	8.00	17.50	11.31	24.38	3.69	1.81	14.00	19.31	22.81	17.50	9.38
14.00	7.00	20.38	11.56	25.75	3.69	2.06	16.38	22.44	26.44	20.375	10.50
	9.00	20.38	11.56	25.75	3.69	2.06	16.38	22.44	26.44	20.375	10.50
16.00	9.00	23.38	12.50	29.25	4.13	2.31	18.88	25.69	25.69	23.375	12.63
	10.00	23.38	12.50	29.25	4.13	2.31	18.88	25.69	25.69	23.375	12.63

All dimensions are in inches.

\* Add stroke to these dimensions.

# Mounting Style and Installation

## Dimensions

### CM Cap Clevis Mount

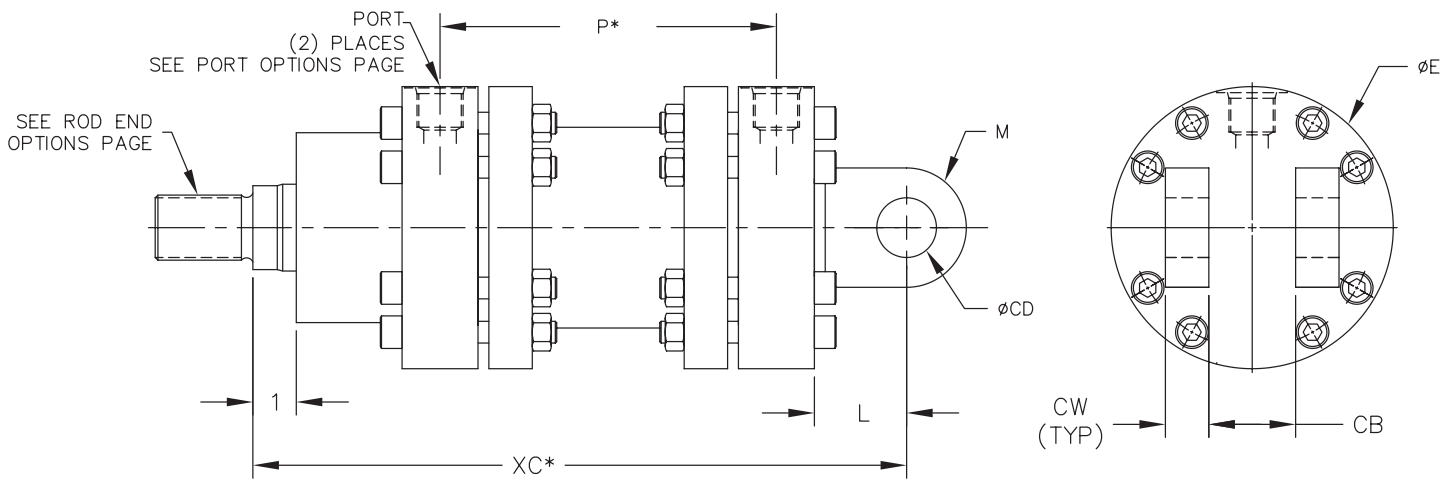

#### EM20-CM (2000 Psi) / EM02-CM (250 Psi)

Bore	Rods	E	P*	L	CD	M	CW	CB	XC*
2.00	1.00	3.88	3.75	1.25	0.750	0.75	0.63	1.25	8.63
	1.38	3.88	3.75	1.25	0.750	0.75	0.63	1.25	8.63
3.00	1.38	5.19	4.25	1.50	1.000	1.00	0.75	1.50	10.13
	2.00	5.19	4.25	1.50	1.000	1.00	0.75	1.50	10.13
4.00	1.75	6.25	4.50	2.13	1.375	1.38	1.00	2.00	11.75
	2.50	6.25	4.50	2.13	1.375	1.38	1.00	2.00	11.75
5.00	2.00	7.88	5.50	2.25	1.750	1.75	1.25	2.50	13.88
	3.50	7.88	5.50	2.25	1.750	1.75	1.25	2.50	13.88
6.00	2.50	9.25	6.25	2.50	2.000	2.00	1.25	2.50	15.38
	4.00	9.25	6.25	2.50	2.000	2.00	1.25	2.50	15.38
7.00	3.00	10.75	6.38	3.00	2.500	2.50	1.50	3.00	16.63
	5.00	10.75	6.38	3.00	2.500	2.50	1.50	3.00	16.63
8.00	3.50	12.00	7.75	3.25	3.000	3.00	1.50	3.00	18.88
	5.50	12.00	7.75	3.25	3.000	3.00	1.50	3.00	18.88

#### EM30-CM (3000 Psi)

Bore	Rods	E	P*	L	CD	M	CW	CB	XC*
3.00	1.75	5.19	4.50	1.50	1.000	1.00	0.75	1.50	11.13
	2.00	5.19	4.50	1.50	1.000	1.00	0.75	1.50	11.13
4.00	2.00	6.25	4.75	2.13	1.375	1.38	1.00	2.00	12.06
	2.50	6.25	4.75	2.13	1.375	1.38	1.00	2.00	12.06
5.00	2.50	7.88	5.75	2.25	1.750	1.75	1.25	2.50	14.75
	3.50	7.88	5.75	2.25	1.750	1.75	1.25	2.50	14.75
6.00	3.00	9.25	6.50	2.50	2.000	2.00	1.25	2.50	16.63
	4.00	9.25	6.50	2.50	2.000	2.00	1.25	2.50	16.63
7.00	3.50	10.75	7.12	3.00	2.500	2.50	1.50	3.00	18.88
	5.00	10.75	7.12	3.00	2.500	2.50	1.50	3.00	18.88
8.00	4.00	12.25	8.50	3.25	3.000	3.00	1.50	3.00	21.69
	5.50	12.25	8.50	3.25	3.000	3.00	1.50	3.00	21.69

All dimensions are in inches.

\* Add stroke to these dimensions.

# Mounting Style and Installation

## Dimensions

### CM Cap Clevis Mount

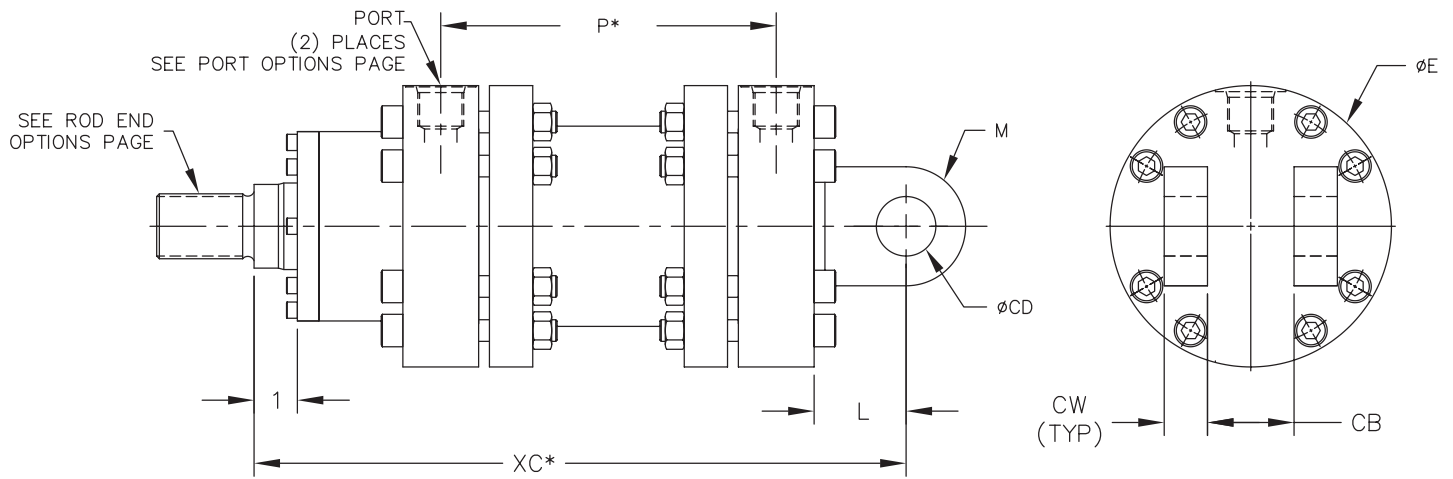

#### EM20-CM (2000 Psi) / EM02-CM (250 Psi)

Bore	Rods	E	P*	XC*	M	CD	L	CW	CB
10.00	4.00	14.94	9.25	21.44	3.50	3.500	4.00	2.00	4.00
	5.50	14.94	9.25	21.44	3.50	3.500	4.00	2.00	4.00
12.00	7.00	17.19	10.44	24.25	4.00	4.000	4.50	2.25	4.50
	7.00	17.19	10.44	24.25	4.00	4.000	4.50	2.25	4.50
14.00	7.00	19.50	10.69	27.25	5.00	5.000	5.75	3.00	6.00
	9.00	19.50	10.69	27.25	5.00	5.000	5.75	3.00	6.00
16.00	9.00	23.38	11.63	30.88	6.00	6.000	7.00	3.50	7.00
	10.00	23.38	11.63	30.88	6.00	6.000	7.00	3.50	7.00

#### EM30-CM (3000 Psi)

Bore	Rods	E	P*	XC*	M	CD	L	CW	CB
10.00	5.00	14.94	10.50	26.44	3.50	3.500	4.00	2.00	4.00
	7.00	14.94	10.50	26.44	3.50	3.500	4.00	2.00	4.00
12.00	5.50	17.50	11.31	28.88	4.00	4.000	4.50	2.25	4.50
	8.00	17.50	11.31	28.88	4.00	4.000	4.50	2.25	4.50
14.00	7.00	20.38	11.56	31.50	5.00	5.000	5.75	3.00	6.00
	9.00	20.38	11.56	31.50	5.00	5.000	5.75	3.00	6.00
16.00	9.00	23.38	12.50	36.25	6.00	6.000	7.00	3.50	7.00
	10.00	23.38	12.50	36.25	6.00	6.000	7.00	3.50	7.00

All dimensions are in inches.

\* Add stroke to these dimensions.

# Mounting Style and Installation

## Dimensions

### CS Spherical Bearing Mount

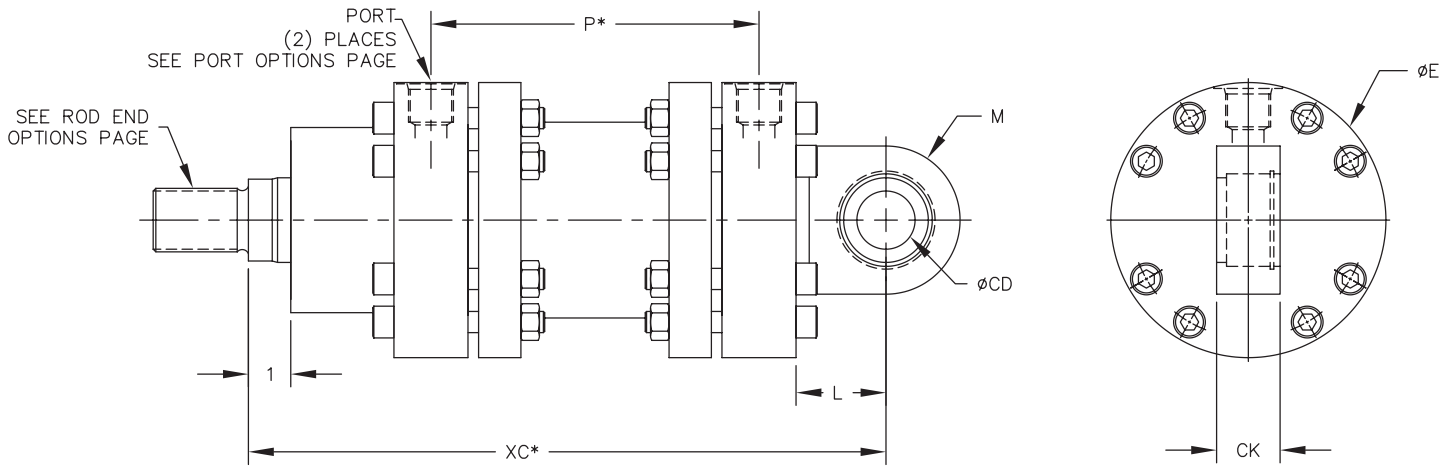

#### EM20-CS(2000 Psi) / EM02-CS(250 Psi)

Bore	Rods	E	$P^*$	L	CD	M	CK	$XC^*$
2.00	1.00	3.88	3.75	1.25	0.750	1.25	0.63	8.63
	1.38	3.88	3.75	1.25	0.750	1.25	0.63	8.63
3.00	1.38	5.19	4.25	1.50	1.000	1.63	1.00	10.13
	2.00	5.19	4.25	1.50	1.000	1.63	1.00	10.13
4.00	1.75	6.25	4.50	2.13	1.375	1.75	1.50	11.75
	2.50	6.25	4.50	2.13	1.375	1.75	1.50	11.75
5.00	2.00	7.88	5.50	2.25	1.750	2.50	1.75	13.88
	3.50	7.88	5.50	2.25	1.750	2.50	1.75	13.88
6.00	2.50	9.25	6.25	2.50	2.000	2.75	2.00	15.38
	4.00	9.25	6.25	2.50	2.000	2.75	2.00	15.38
7.00	3.00	10.75	6.38	3.00	2.500	3.00	2.50	16.63
	5.00	10.75	6.38	3.00	2.500	3.00	2.50	16.63
8.00	3.50	12.00	7.75	3.25	3.000	3.44	3.00	18.88
	5.50	12.00	7.75	3.25	3.000	3.44	3.00	18.88

#### EM30-CS(3000 Psi)

Bore	Rods	E	$P^*$	L	CD	M	CK	$XC^*$
3.00	1.75	5.19	4.50	1.50	1.000	1.63	1.00	11.13
	2.00	5.19	4.50	1.50	1.000	1.63	1.00	11.13
4.00	2.00	6.25	4.75	2.13	1.375	1.75	1.50	12.06
	2.50	6.25	4.75	2.13	1.375	1.75	1.50	12.06
5.00	2.50	7.88	5.75	2.25	1.750	2.50	1.75	14.75
	3.50	7.88	5.75	2.25	1.750	2.50	1.75	14.75
6.00	3.00	9.25	6.50	2.50	2.000	2.75	2.00	16.63
	4.00	9.25	6.50	2.50	2.000	2.75	2.00	16.63
7.00	3.50	10.75	7.12	3.00	2.500	3.00	2.50	18.88
	5.00	10.75	7.12	3.00	2.500	3.00	2.50	18.88
8.00	4.00	12.25	8.50	3.25	3.000	3.44	3.00	21.69
	5.50	12.25	8.50	3.25	3.000	3.44	3.00	21.69

All dimensions are in inches.

\* Add stroke to these dimensions.



# Mounting Style and Installation

## Dimensions

### CS Spherical Bearing Mount

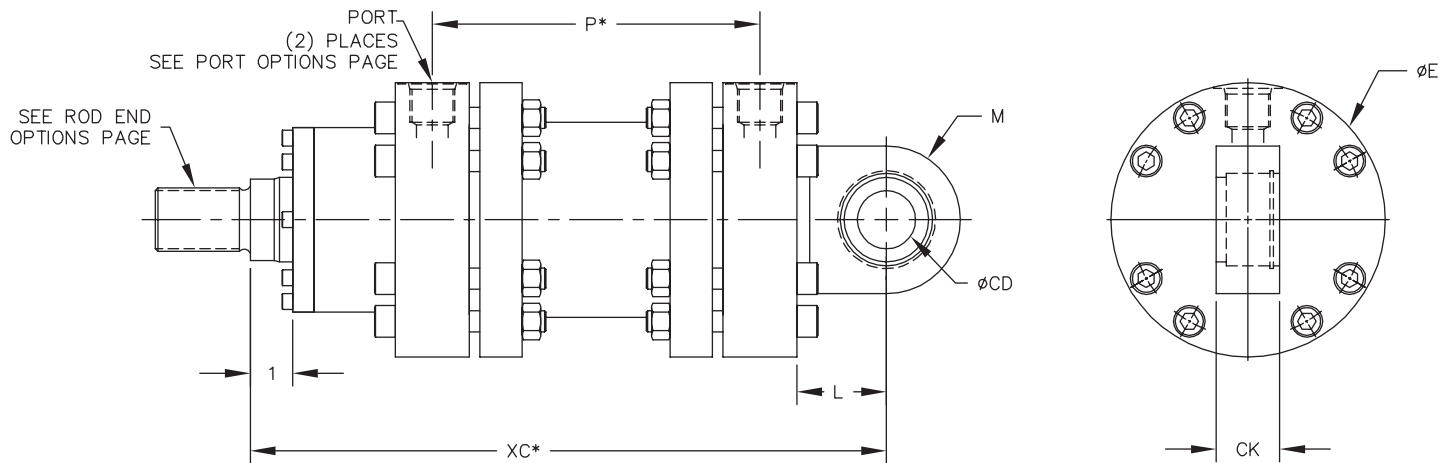

#### EM20-CS(2000 Psi) / EM02-CS (250 Psi)

Bore	Rods	E	P*	XC*	M	CD	L	CK
10.00	4.00	14.94	9.25	21.44	5.50	3.500	4.00	3.19
	5.50	14.94	9.25	21.44	5.50	3.500	4.00	3.19
12.00	5.50	17.19	10.44	24.25	6.00	4.000	4.50	3.50
	7.00	17.19	10.44	24.25	6.00	4.000	4.50	3.50
14.00	7.00	19.50	10.69	27.25	6.75	5.000	5.75	4.25
	9.00	19.50	10.69	27.25	6.75	5.000	5.75	4.25
16.00	9.00	23.38	11.63	30.88	7.50	6.000	7.00	4.63
	10.00	23.38	11.63	30.88	7.50	6.000	7.00	4.63

#### EM30-CS (3000 Psi)

Bore	Rods	E	P*	XC*	M	CD	L	CK
10.00	5.00	14.94	10.50	26.44	5.50	3.500	4.00	3.19
	7.00	14.94	10.50	26.44	5.50	3.500	4.00	3.19
12.00	5.50	17.50	11.31	28.88	6.00	4.000	4.50	3.50
	8.00	17.50	11.31	28.88	6.00	4.000	4.50	3.50
14.00	7.00	20.38	11.56	31.50	6.75	5.000	5.75	4.25
	9.00	20.38	11.56	31.50	6.75	5.000	5.75	4.25
16.00	9.00	23.38	12.50	36.25	7.50	6.000	7.00	4.63
	10.00	23.38	12.50	36.25	7.50	6.000	7.00	4.63

All dimensions are in inches.

\* Add stroke to these dimensions.

# Mounting Style and Installation

## Dimensions

### PS Cap Rectangular Mount

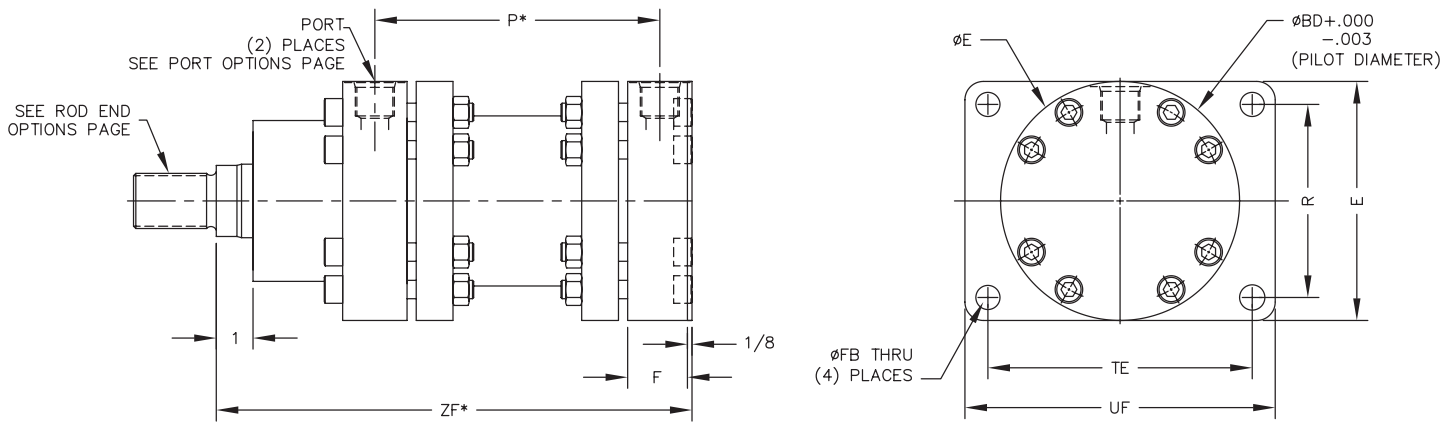

#### EM20-PS (2000 Psi) / EM02-PS (250 Psi)

Bore	Rods	E	P*	ZF*	F	FB	R	TE	UF	BD
2.00	1.00	3.88	3.75	7.38	1.50	0.41	3.13	4.25	5.00	3.875
	1.38	3.88	3.75	7.38	1.50	0.41	3.13	4.25	5.00	3.875
3.00	1.38	5.19	4.25	8.63	1.63	0.56	4.19	5.75	6.75	5.188
	2.00	5.19	4.25	8.63	1.63	0.56	4.19	5.75	6.75	5.188
4.00	1.75	6.25	4.50	9.63	1.63	0.69	5.00	6.94	8.19	6.250
	2.50	6.25	4.50	9.63	1.63	0.69	5.00	6.94	8.19	6.250
5.00	2.00	7.88	5.50	11.63	2.13	0.81	6.38	8.69	10.19	7.875
	3.50	7.88	5.50	11.63	2.13	0.81	6.38	8.69	10.19	7.875
6.00	2.50	9.25	6.25	12.88	2.50	1.06	7.25	10.31	12.31	9.250
	4.00	9.25	6.25	12.88	2.50	1.06	7.25	10.31	12.31	9.250
7.00	3.00	10.75	6.38	13.63	2.50	1.19	8.38	11.94	14.19	10.750
	5.00	10.75	6.38	13.63	2.50	1.19	8.38	11.94	14.19	10.750
8.00	3.50	12.00	7.75	15.63	3.38	1.31	9.50	13.31	15.81	12.000
	5.50	12.00	7.75	15.63	3.38	1.31	9.50	13.31	15.81	12.000

#### EM30-PS (3000 Psi)

Bore	Rods	E	P*	ZF*	F	FB	R	TE	UF	BD
3.00	1.75	5.19	4.50	9.63	1.63	0.56	4.19	5.75	6.75	5.187
	2.00	5.19	4.50	9.63	1.63	0.56	4.19	5.75	6.75	5.187
4.00	2.00	6.50	4.75	9.94	1.63	0.69	5.25	7.19	8.44	6.498
	2.50	6.50	4.75	9.94	1.63	0.69	5.25	7.19	8.44	6.498
5.00	2.50	7.88	5.75	12.50	2.13	0.81	6.38	8.69	10.19	7.875
	3.50	7.88	5.75	12.50	2.13	0.81	6.38	8.69	10.19	7.875
6.00	3.00	9.25	6.50	14.13	2.50	1.06	7.25	10.31	12.25	9.250
	4.00	9.25	6.50	14.13	2.50	1.06	7.25	10.31	12.25	9.250
7.00	3.50	10.75	7.12	15.88	2.50	1.19	8.50	11.94	14.19	10.750
	5.00	10.75	7.12	15.88	2.50	1.19	8.50	11.94	14.19	10.750
8.00	4.00	12.25	8.50	18.44	3.38	1.31	9.88	13.69	16.19	12.375
	5.50	12.25	8.50	18.44	3.38	1.31	9.88	13.69	16.19	12.375

All dimensions are in inches.

\* Add stroke to these dimensions.

# Mounting Style and Installation

## Dimensions

### PS Cap Rectangular Mount

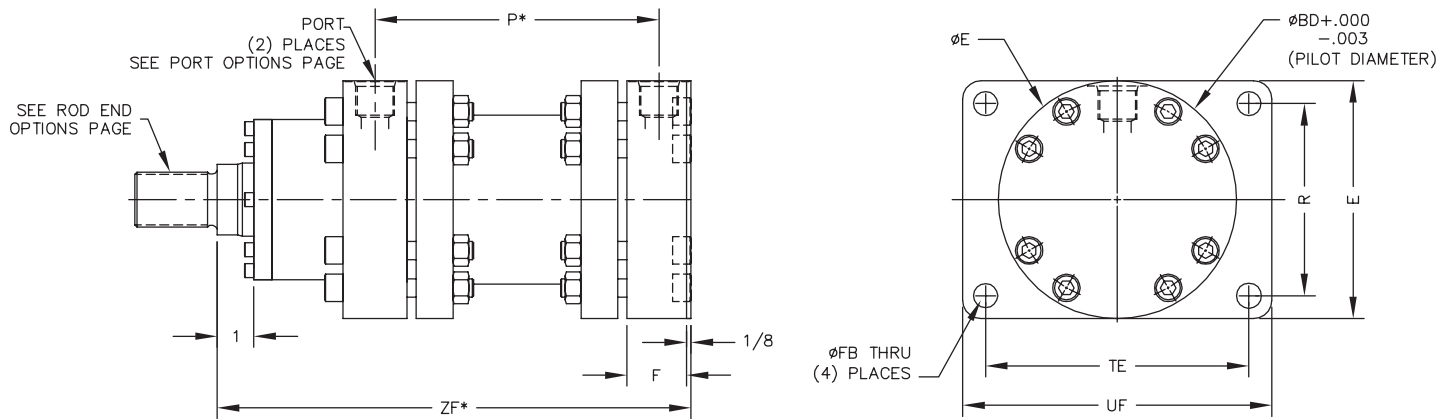

#### EM20-PS (2000 Psi) / EM02-PS (250 Psi)

Bore	Rods	E	P*	ZF*	F	FB	R	TE	UF	BD
10.00	4.00	14.94	9.25	17.44	3.38	1.56	11.94	16.50	19.50	14.937
	5.50	14.94	9.25	17.44	3.38	1.56	11.94	16.50	19.50	14.937
12.00	5.50	17.19	10.44	19.75	3.69	1.81	13.69	19.00	22.50	17.187
	7.00	17.19	10.44	19.75	3.69	1.81	13.69	19.00	22.50	17.187
14.00	7.00	19.50	10.69	21.50	3.69	2.06	15.50	21.56	25.56	19.500
	9.00	19.50	10.69	21.50	3.69	2.06	15.50	21.56	25.56	19.500
16.00	9.00	23.38	11.19	23.88	4.13	2.31	18.88	25.69	30.19	23.000
	10.00	23.38	11.19	23.88	4.13	2.31	18.88	25.69	30.19	23.000

#### EM30-PS (3000 Psi)

Bore	Rods	E	P*	ZF*	F	FB	R	TE	UF	BD
10.00	5.00	14.94	10.50	21.44	3.38	1.56	11.94	16.50	19.50	14.937
	7.00	14.94	10.50	21.44	3.38	1.56	11.94	16.50	19.50	14.937
12.00	5.50	17.50	11.31	24.38	3.69	1.81	14.00	19.31	22.81	17.500
	8.00	17.50	11.31	24.38	3.69	1.81	14.00	19.31	22.81	17.500
14.00	7.00	20.38	11.56	25.75	3.69	2.06	16.38	22.44	26.44	20.375
	9.00	20.38	11.56	25.75	3.69	2.06	16.38	22.44	26.44	20.375
16.00	9.00	23.38	12.50	29.25	4.13	2.31	18.88	25.69	30.19	23.375
	10.00	23.38	12.50	29.25	4.13	2.31	18.88	25.69	30.19	23.375

All dimensions are in inches.

\* Add stroke to these dimensions.

# Mounting Style and Installation Dimensions

## TS Intermediate Trunnion Mount

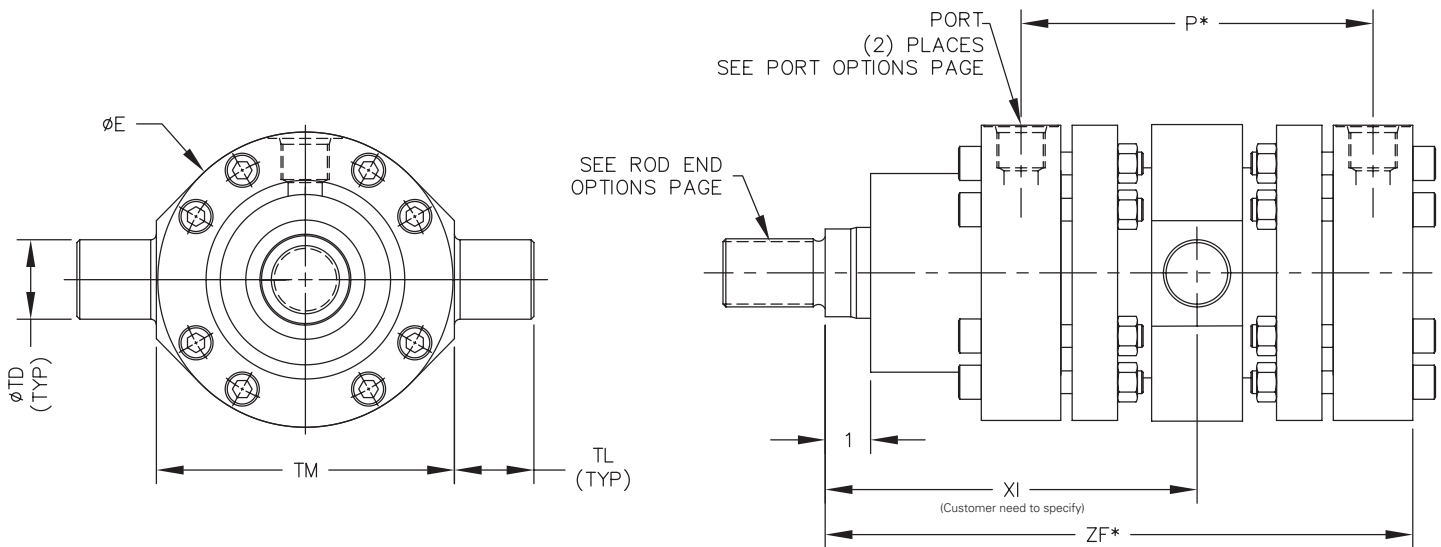

### EM20-TS (2000 Psi) / EM02-TS (250 Psi)

Bore	Rods	E	P*	ZF*	TD	TL	TM
2.00	1.00	3.88	3.75	7.38	1.250	1.25	3.94
	1.38	3.88	3.75	7.38	1.250	1.25	3.94
3.00	1.38	5.19	4.25	8.63	1.500	1.50	5.25
	2.00	5.19	4.25	8.63	1.500	1.50	5.25
4.00	1.75	6.25	4.50	9.63	2.000	2.00	6.31
	2.50	6.25	4.50	9.63	2.000	2.00	6.31
5.00	2.00	7.88	5.50	11.63	2.500	2.50	7.94
	3.50	7.88	5.50	11.63	2.500	2.50	7.94
6.00	2.50	9.25	6.25	12.88	3.000	3.00	9.31
	4.00	9.25	6.25	12.88	3.000	3.00	9.31
7.00	3.00	10.75	6.38	13.63	3.500	3.50	10.81
	5.00	10.75	6.38	13.63	3.500	3.50	10.81
8.00	3.50	12.00	7.75	15.63	4.000	4.00	12.06
	5.50	12.00	7.75	15.63	4.000	4.00	12.06

### EM30-TS (3000 Psi)

Bore	Rods	E	P*	ZF*	TD	TL	TM
3.00	1.75	5.19	4.50	9.63	1.500	1.50	5.25
	2.00	5.19	4.50	9.63	1.500	1.50	5.25
4.00	2.00	6.25	4.75	9.94	2.000	2.00	6.56
	2.50	6.25	4.75	9.94	2.000	2.00	6.56
5.00	2.50	7.88	5.75	12.50	2.500	2.50	7.94
	3.50	7.88	5.75	12.50	2.500	2.50	7.94
6.00	3.00	9.25	6.50	14.13	3.000	3.00	9.31
	4.00	9.25	6.50	14.13	3.000	3.00	9.31
7.00	3.50	10.75	7.12	15.88	3.500	3.50	10.81
	5.00	10.75	7.12	15.88	3.500	3.50	10.81
8.00	4.00	12.25	8.50	18.44	4.000	4.00	12.44
	5.50	12.25	8.50	18.44	4.000	4.00	12.44

All dimensions are in inches.

\* Add stroke to these dimensions.

# Mounting Style and Installation Dimensions

## TS Intermediate Trunnion Mount

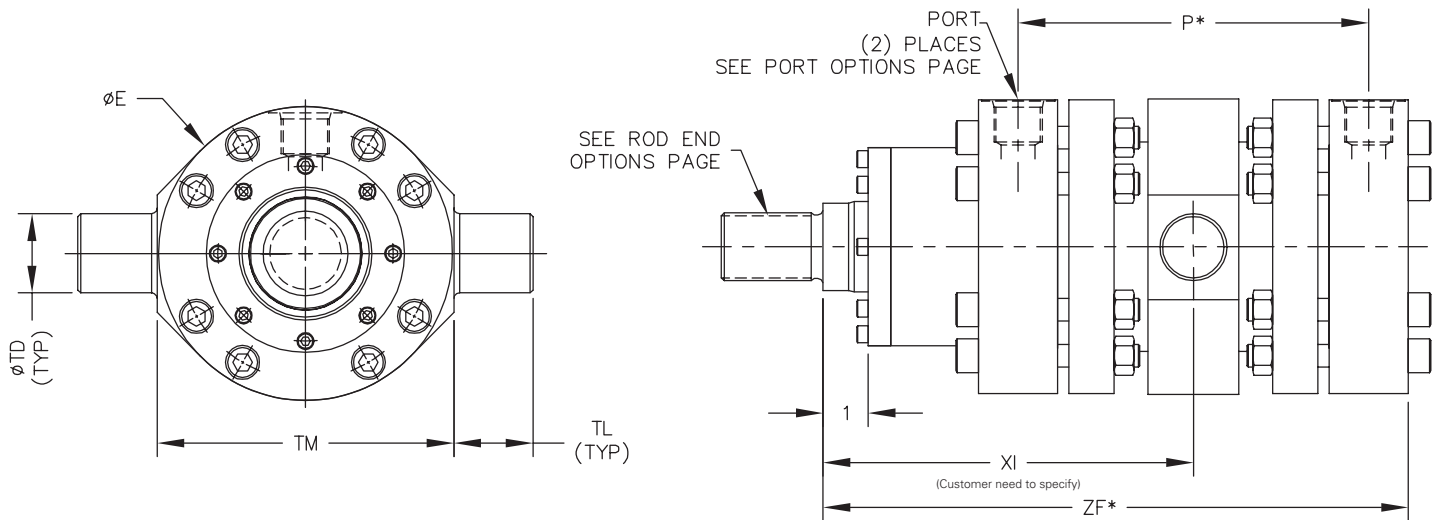

### EM20-TS (2000 Psi) / EM02-TS (250 Psi)

Bore	Rods	E	P*	ZF*	TD	TL	TM
10.00	4.00	14.94	9.25	17.44	5.00	5.00	15.00
	5.50	14.94	9.25	17.44	5.00	5.00	15.00
12.00	5.50	17.19	10.44	19.75	6.00	6.00	17.25
	7.00	17.19	10.44	19.75	6.00	6.00	17.25
14.00	7.00	19.50	10.69	21.50	7.00	7.00	19.56
	9.00	19.50	10.69	21.50	7.00	7.00	19.56
16.00	9.00	23.38	11.63	23.88	8.00	8.00	23.44
	10.00	23.38	11.63	23.88	8.00	8.00	23.44

### EM30-TS (3000 Psi)

Bore	Rods	E	P*	ZF*	TD	TL	TM
10.00	5.00	14.94	10.50	21.44	5.00	5.00	15.00
	7.00	14.94	10.50	21.44	5.00	5.00	15.00
12.00	5.50	17.50	11.31	24.38	7.50	7.50	17.56
	8.00	17.50	11.31	24.38	7.50	7.50	17.56
14.00	7.00	20.38	11.56	25.75	8.50	8.50	20.44
	9.00	20.38	11.56	25.75	8.50	8.50	20.44
16.00	9.00	23.38	12.50	29.25	9.50	9.50	23.44
	10.00	23.38	12.50	29.25	9.50	9.50	23.44

All dimensions are in inches.

\* Add stroke to these dimensions.

# Mounting Style and Installation Dimensions

## US Head Trunnion Mount

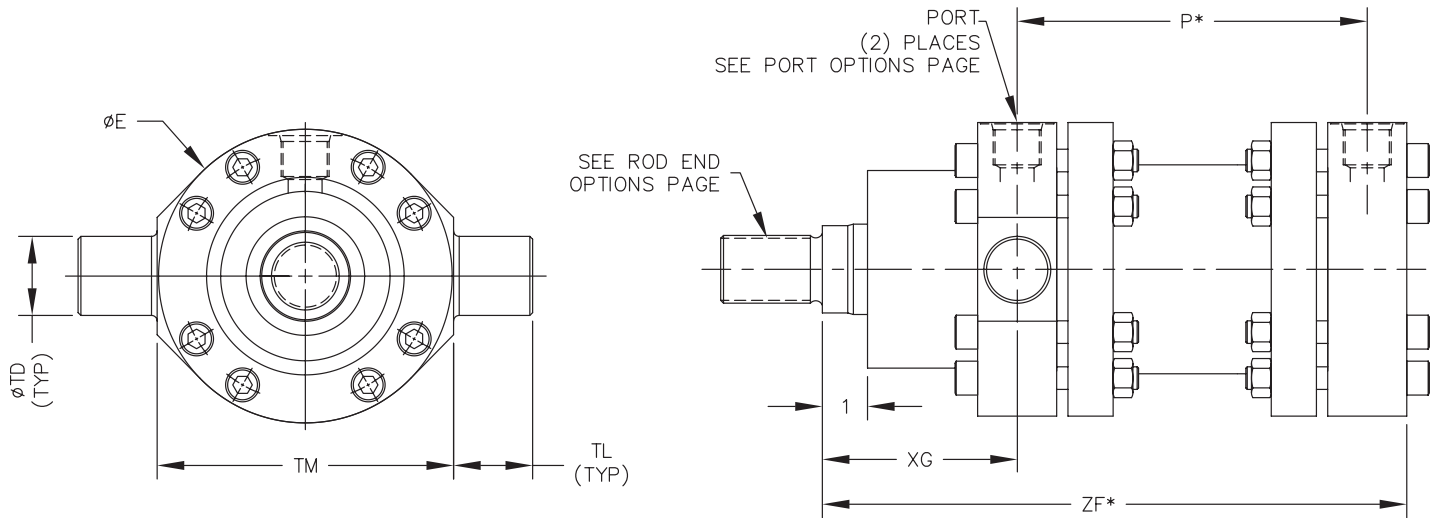

### EM20-US (2000 Psi) / EM02-US (250 Psi)

Bore	Rods	E	P*	ZF*	TD	TL	TM	XG
2.00	1.00	3.88	3.75	7.38	1.250	1.25	3.94	2.81
	1.38	3.88	3.75	7.38	1.250	1.25	3.94	2.81
3.00	1.38	5.19	4.25	8.63	1.500	1.50	5.25	3.13
	2.00	5.19	4.25	8.63	1.500	1.50	5.25	3.13
4.00	1.75	6.25	4.50	9.63	2.000	2.00	6.31	3.81
	2.50	6.25	4.50	9.63	2.000	2.00	6.31	3.81
5.00	2.00	7.88	5.50	11.63	2.500	2.50	7.94	4.88
	3.50	7.88	5.50	11.63	2.500	2.50	7.94	4.88
6.00	2.50	9.25	6.25	12.88	3.000	3.00	9.31	5.31
	4.00	9.25	6.25	12.88	3.000	3.00	9.31	5.31
7.00	3.00	10.75	6.38	13.63	3.500	3.50	10.81	5.94
	5.00	10.75	6.38	13.63	3.500	3.50	10.81	5.94
8.00	3.50	12.00	7.75	15.63	4.000	4.00	12.06	6.13
	5.50	12.00	7.75	15.63	4.000	4.00	12.06	6.13

### EM30-US (3000 Psi)

Bore	Rods	E	P*	ZF*	TD	TL	TM	XG
3.00	1.75	5.19	4.50	9.63	1.500	1.50	5.25	4.25
	2.00	5.19	4.50	9.63	1.500	1.50	5.25	4.25
4.00	2.00	6.25	4.75	9.94	2.000	2.00	6.56	4.31
	2.50	6.25	4.75	9.94	2.000	2.00	6.56	4.31
5.00	2.50	7.88	5.75	12.50	2.500	2.50	7.94	5.63
	3.50	7.88	5.75	12.50	2.500	2.50	7.94	5.63
6.00	3.00	9.25	6.50	14.13	3.000	3.00	9.31	6.31
	4.00	9.25	6.50	14.13	3.000	3.00	9.31	6.31
7.00	3.50	10.75	7.12	15.88	3.500	3.50	10.81	7.44
	5.00	10.75	7.12	15.88	3.500	3.50	10.81	7.44
8.00	4.00	12.25	8.50	18.44	4.000	4.00	12.44	8.19
	5.50	12.25	8.50	18.44	4.000	4.00	12.44	8.19

All dimensions are in inches.

\* Add stroke to these dimensions.

# Mounting Style and Installation Dimensions

## FS Head Circular Flange Mount

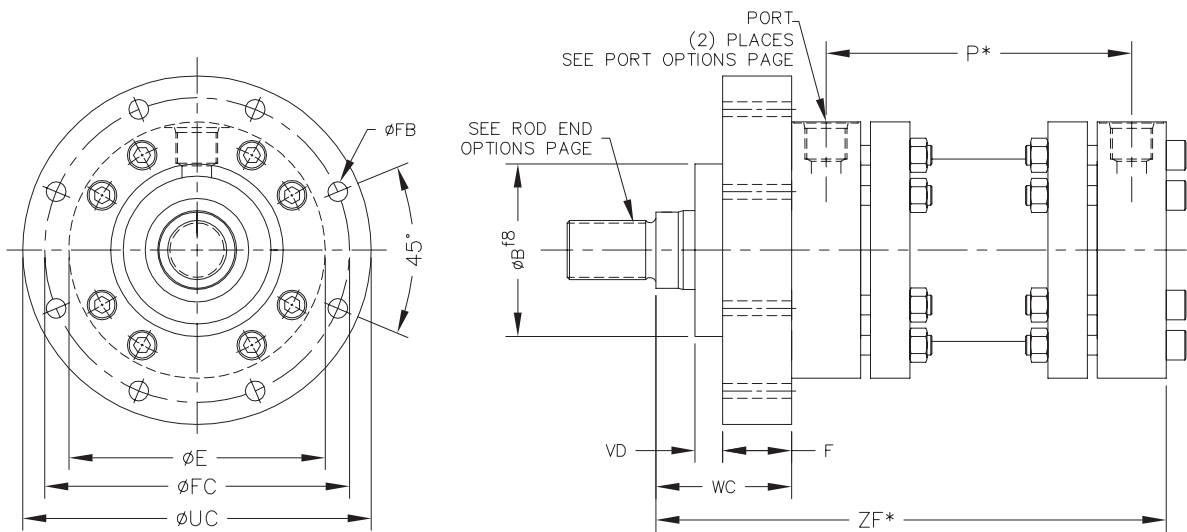

### EM20-FS (2000 Psi) / EM02-TS (250 Psi)

Bore	Rods	E	P*	ZF*	UC	F	WC	VD	FB	FC	B
2.00	1.00	3.88	3.75	7.38	5.83	0.75	1.44	0.44	0.46	4.960	3.125
	1.38	3.88	3.75	7.38	5.83	0.75	1.44	0.44	0.46	4.960	3.125
3.00	1.38	5.19	4.25	8.63	7.63	1.25	1.38	0.38	0.66	6.496	3.750
	2.00	5.19	4.25	8.63	7.63	1.25	1.38	0.38	0.66	6.496	3.750
4.00	1.75	6.25	4.50	9.63	9.38	1.25	2.25	1.25	0.78	7.874	4.375
	2.50	6.25	4.50	9.63	9.38	1.25	2.25	1.25	0.78	7.874	4.375
5.00	2.00	7.88	5.50	11.63	10.70	1.25	2.63	1.63	0.78	9.252	6.125
	3.50	7.88	5.50	11.63	10.70	1.25	2.63	1.63	0.78	9.252	6.125
6.00	2.50	9.25	6.25	12.88	12.44	1.50	2.50	1.50	0.78	11.024	6.875
	4.00	9.25	6.25	12.88	12.44	1.50	2.50	1.50	0.78	11.024	6.875
7.00	3.00	10.75	6.38	13.63	13.88	1.58	3.13	2.13	0.78	12.188	8.000
	5.00	10.75	6.38	13.63	13.88	1.58	3.13	2.13	0.78	12.188	8.000
8.00	3.50	12.00	7.75	15.63	15.16	1.58	2.80	1.80	1.03	13.386	8.000
	5.50	12.00	7.75	15.63	15.16	1.58	2.80	1.80	1.03	13.386	8.000

### EM30-FS (3000 Psi)

Bore	Rods	E	P*	ZF*	UC	F	WC	VD	FB	FC	B
3.00	1.75	5.19	4.50	9.63	8.25	1.25	1.63	0.63	0.66	7.087	3.750
	2.00	5.19	4.50	9.63	8.25	1.25	1.63	0.63	0.66	7.087	3.750
4.00	2.00	6.25	4.75	9.94	9.85	1.50	1.44	0.44	0.78	8.346	4.375
	2.50	6.25	4.75	9.94	9.85	1.50	1.44	0.44	0.78	8.346	4.375
5.00	2.50	7.88	5.75	12.50	11.44	1.58	2.43	1.43	0.78	9.843	6.125
	3.50	7.88	5.75	12.50	11.44	1.58	2.43	1.43	0.78	9.843	6.125
6.00	3.00	9.25	6.50	14.13	14.18	1.80	2.45	1.45	1.03	12.401	6.875
	4.00	9.25	6.50	14.13	14.18	1.80	2.45	1.45	1.03	12.401	6.875
7.00	3.50	10.75	7.12	15.88	15.95	2.00	3.38	2.38	1.28	13.780	8.000
	5.00	10.75	7.12	15.88	15.95	2.00	3.38	2.38	1.28	13.780	8.000
8.00	4.00	12.25	8.50	18.44	17.35	2.25	3.44	2.44	1.28	15.160	8.500
	5.50	12.25	8.50	18.44	17.35	2.25	3.44	2.44	1.28	15.160	8.500

All dimensions are in inches.

\* Add stroke to these dimensions.

# Mounting Style and Installation

## Dimensions

### KS Basic No Mount

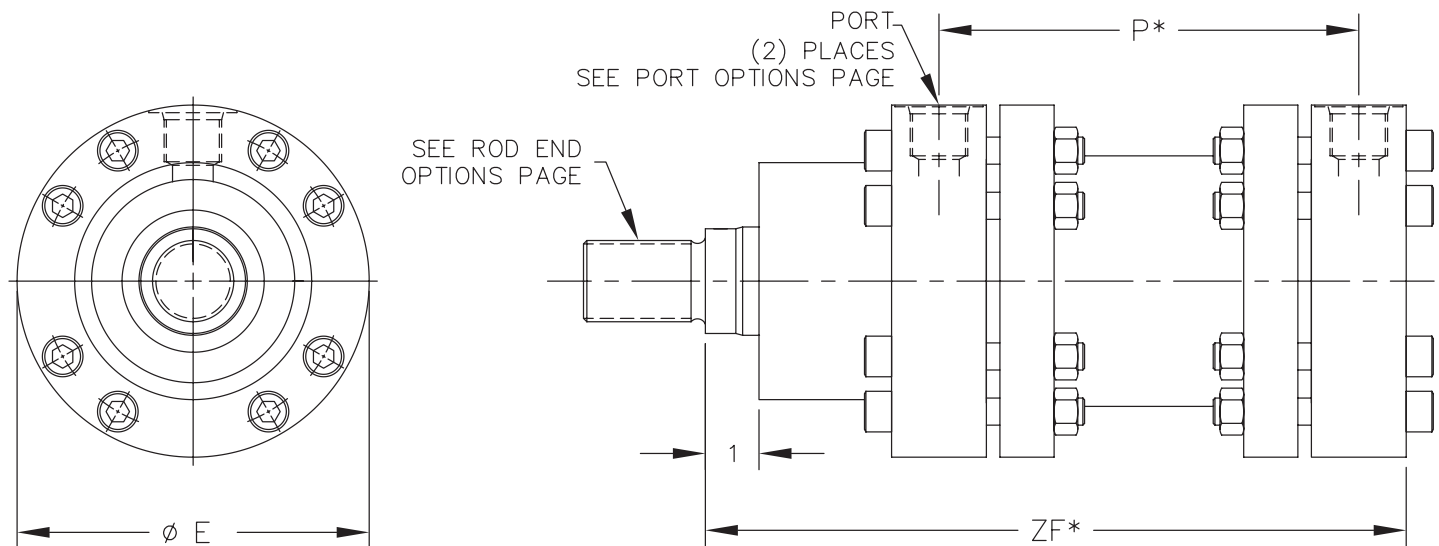

#### EM20-KS (2000 Psi) / EM02-KS (250 Psi)

Bore	Rods	E	P*	ZF*
2.00	1.00	3.88	3.75	7.38
	1.38	3.88	3.75	7.38
3.00	1.38	5.19	4.25	8.63
	2.00	5.19	4.25	8.63
4.00	1.75	6.25	4.50	9.63
	2.50	6.25	4.50	9.63
5.00	2.00	7.88	5.50	11.63
	3.50	7.88	5.50	11.63
6.00	2.50	9.25	6.25	12.88
	4.00	9.25	6.25	12.88
7.00	3.00	10.75	6.38	13.63
	5.00	10.75	6.38	13.63
8.00	3.50	12.00	7.75	15.63
	5.50	12.00	7.75	15.63

#### EM30-KS (3000 Psi)

Bore	Rods	E	P*	ZF*
3.00	1.75	5.19	4.50	9.63
	2.00	5.19	4.50	9.63
4.00	2.00	6.25	4.75	9.94
	2.50	6.25	4.75	9.94
5.00	2.50	7.88	5.75	12.50
	3.50	7.88	5.75	12.50
6.00	3.00	9.25	6.50	14.13
	4.00	9.25	6.50	14.13
7.00	3.50	10.75	7.12	15.88
	5.00	10.75	7.12	15.88
8.00	4.00	12.25	8.50	18.44
	5.50	12.25	8.50	18.44

All dimensions are in inches.

\* Add stroke to these dimensions.



# Mounting Style and Installation

## Dimensions

### KS Basic No Mount

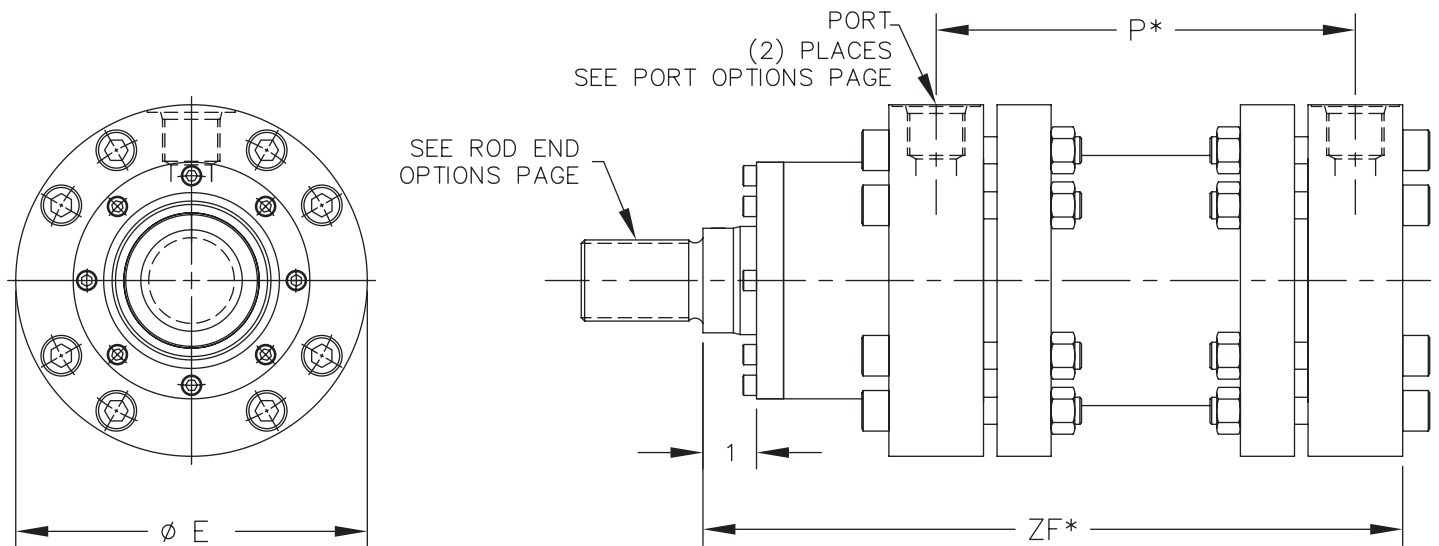

#### EM20-KS (2000 Psi) / EM02-KS (250 Psi)

Bore	Rods	E	P*	ZF*
10.00	4.00	14.94	9.25	17.44
	5.50	14.94	9.25	17.44
12.00	5.50	17.19	10.44	19.75
	7.00	17.19	10.44	19.75
14.00	7.00	19.50	10.69	21.50
	9.00	19.50	10.69	21.50
16.00	9.00	23.38	11.63	23.88
	10.00	23.38	11.63	23.88

#### EM30-KS (3000 Psi)

Bore	Rods	E	P*	ZF*
10.00	5.00	14.94	10.50	21.44
	7.00	14.94	10.50	21.44
12.00	5.50	17.50	11.31	24.38
	8.00	17.50	11.31	24.38
14.00	7.00	20.38	11.56	25.75
	9.00	20.38	11.56	25.75
16.00	9.00	23.38	12.50	29.25
	10.00	23.38	12.50	29.25

All dimensions are in inches.

\* Add stroke to these dimensions.

# Mounting Accessories

All rod accessories must be torqued against the rod shoulder. Mounting brackets, rod clevises, and rod eyes for all Series EM cylinders are available from Eaton. These accessories are detailed below showing part numbers and all pertinent dimensional data.

Make sure the rod end type selected has threads that match the threads of any required accessory. Dimensions are in inches unless otherwise noted. When ordering, please specify the part name and part number.

## Spherical Rod Eye<sup>1</sup>

Part No.	KK	A	CD +.0000 -.0005	CE	EX	ER	JL	LE	Load Capacity (lbs)
BRE-0750	3/4-16	1.00	0.7500	1.25	0.66	1.25	1.31	1.06	9400
BRE-1000	1-14	1.50	1.0000	1.88	0.88	1.38	1.50	1.44	16800
BRE-1250	1 1/4-12	2.00	1.3750	2.13	1.19	1.81	2.00	1.88	28600
BRE-1500	1 1/2-12	2.13	1.7500	2.50	1.53	2.19	2.25	2.13	43000
BRE-1875	1 7/8-12	2.88	2.0000	2.75	1.75	2.63	2.75	2.50	70000

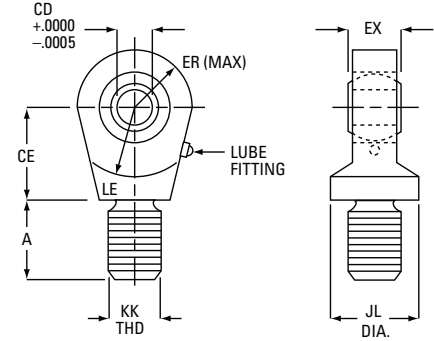

## Pivot Pin - for Spherical Bearing<sup>2</sup>

Part No.	CD	CL
SBPIN-075-10	0.750	2.03
SBPIN-100-10	1.000	2.50
SBPIN-138-10	1.375	3.31
SBPIN-175-10	1.750	4.22
SBPIN-200-10	2.000	4.94

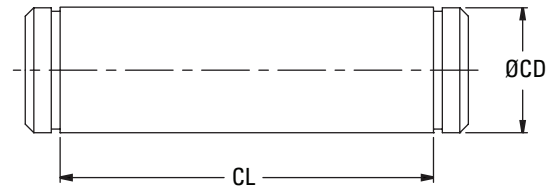

## Spherical Clevis Bracket

Part No.	BA	CB	CD	CW	DD	E	FH	FL	LR	M	MR
SCB-0750	2.76	0.66	0.750	0.62	0.53	3.75	0.62	2.00	1.38	0.88	1.00
SCB-1000	4.10	0.88	1.000	0.75	0.53	5.50	0.75	2.50	1.69	1.00	1.19
SCB-1380	4.95	1.19	1.375	1.00	0.66	6.50	0.88	3.50	2.44	1.38	1.62
SCB-1750	6.58	1.53	1.750	1.25	0.91	8.50	1.25	4.50	2.88	1.75	2.06
SCB-2000	7.92	1.75	2.000	1.50	0.91	10.62	1.50	5.00	3.31	2.00	2.38

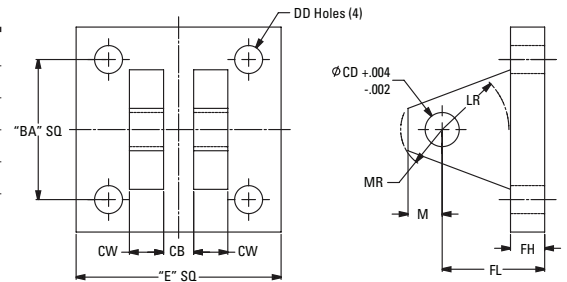

### NOTES:

- Spherical Rod Eye does not include pivot pin, add -10 to the end of the part number to order the Spherical Rod Eye and pivot pin assembly Ex. BRE-XXXX-10
- SBPIN-XXX-10 assemblies includes the retaining clips.

# Mounting Accessories

## Rod Eye

Part Number	A	CA	CB	CD	ER	KK	Static Tensile Load (LB)
FR E-0750	1.13	2.06	1.25	0.75	0.88	.750-16	10,750
FRE-1000	1.63	2.81	1.50	1.00	1.19	1.000-14	16,500
FRE-1250	2.00	3.44	2.00	1.38	1.56	1.250-12	30,500
FRE-1500	2.25	4.00	2.50	1.75	2.00	1.500-12	47,500
FRE-1875	3.00	5.00	2.50	2.00	2.25	1.875-12	55,000
FRE-2250	3.50	5.81	3.00	2.50	2.81	2.250-12	80,000
FRE-2500	3.50	6.13	3.00	3.00	3.25	2.500-12	94,000
FRE-3250	4.50	7.63	4.00	3.50	3.88	3.250-12	1,58,200
FRE-4000	5.50	9.13	4.50	4.00	4.44	4.000-12	2,11,500
FRE-5500	7.00	11.75	6.00	5.00	5.25	5.500-12	3,37,500
FRE-6000	9.00	14.25	7.00	6.00	6.25	6.000-12	4,50,000

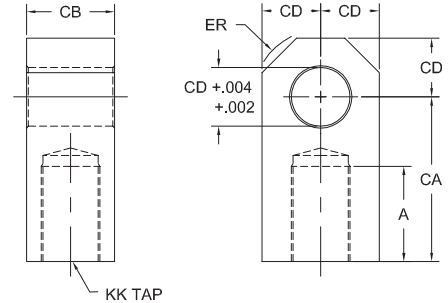

## Rod Clevis

Part Number	CB	CD	CE	CH	CW	ER	KK	L	Static Tensile Load (LB)
FRC-0437	1.25	0.75	2.38	1.38	0.63	0.75	.750-16	1.25	10,750
FRC-0750	1.50	1.00	3.13	1.63	0.75	1.00	1.000-14	1.50	16,500
FRC-1000	2.00	1.38	4.13	2.00	1.00	1.38	1.250-12	2.13	30,500
FRC-1250	2.50	1.75	4.50	2.38	1.25	1.75	1.500-12	2.25	47,500
FRC-1500	2.50	2.00	5.50	2.94	1.25	2.00	1.875-12	2.50	55,000
FRC-1875	3.00	2.50	6.50	3.50	1.50	2.50	2.250-12	3.00	80,000
FRC-2250	3.00	3.00	6.75	3.88	1.50	2.75	2.500-12	3.25	94,000
FRC-2500	4.00	3.50	8.50	5.00	2.00	3.50	3.250-12	4.00	1,58,200
FRC-3250	4.50	4.00	10.00	6.13	2.25	4.00	4.000-12	4.50	2,11,500
FRC-4000	6.00	5.00	12.75	-	3.00	5.25	5.500-12	5.75	3,37,500
FRC-5500	7.00	6.00	15.75	-	3.50	6.25	6.000-12	6.75	4,50,000

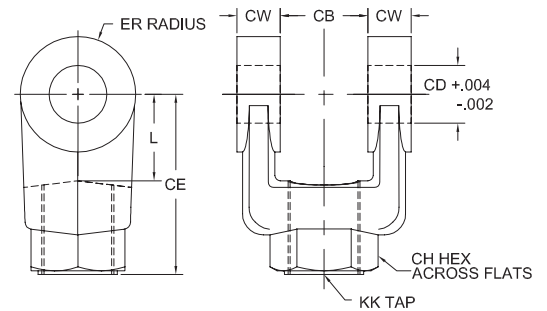

## Pivot Pin

Part Number	CD	CL	ET	Static Shear Load (LB)
SVPIN-075-10	0.75	2.63	2.89	18,425
SVPIN-100-10	1.00	3.13	3.39	32,775
SVPIN-138-10	1.38	4.16	4.47	62,000
SVPIN-175-10	1.75	5.16	5.56	100,425
SVPIN-200-10	2.00	5.16	5.56	131,175
SVPIN-250-10	2.50	6.16	6.64	204,975
SVPIN-300-10	3.00	6.19	6.77	295,175
SVPIN-350-10	3.50	8.13	8.84	401,775
SVPIN-400-10	4.00	9.13	9.86	524,750
SVPIN-500-10	5.00	12.13	12.88	819,950
SVPIN-600-10	6.00	14.25	15.3	1,180,725

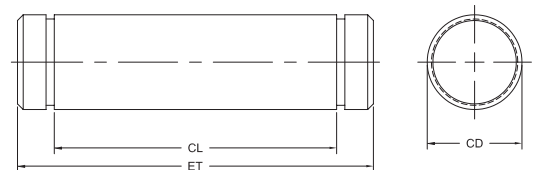

### NOTES:

1. The load listed is max load in tension.
2. The pull load of the cylinder should be less than the listed load for the respective selected rod accessory.
3. Pivot pin is rated in shear.
4. The Accessories selection chart on page 28 is only a guide, select the accessories taking into consideration the pull load of the cylinder and the rated load of the accessory.
5. All rod accessories must be torqued against rod shoulder.
6. Rod Clevis does not include pivot pin, add -10 to the end of the part number to order a clevis and pivot pin assembly Ex. FRC-1000-10
7. SVPIN-XXX-10 assemblies includes the retaining clips.

# Mounting Accessories

## Eye Bracket

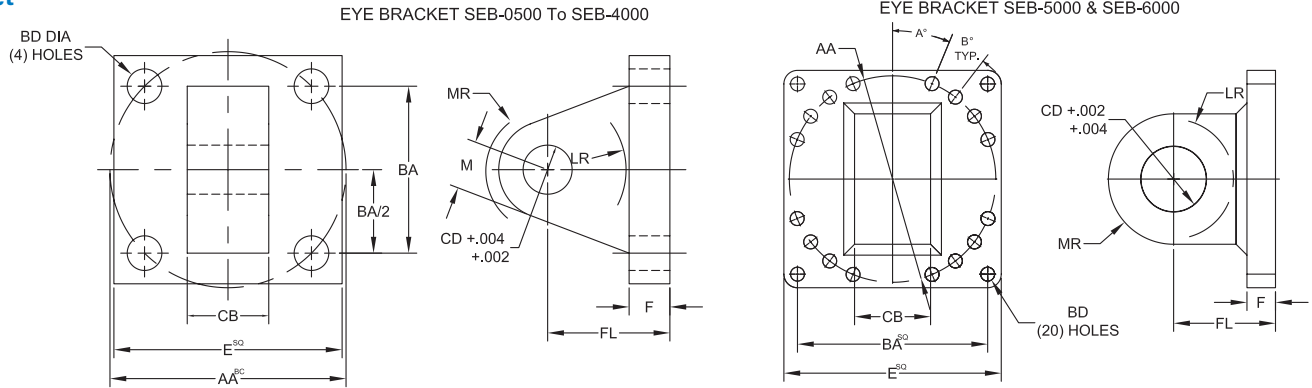

Bore	CB	CD	BD	E	F	FL	LR	M	MR	BA	A°	B°	AA	State Tensile Load
SEB-0500	1.25	0.75	0.53	3.50	0.63	1.88	1.00	0.75	1.06	2.56	-	-	3.60	11,000
SEB-100A	1.50	1.00	0.66	4.50	0.88	2.38	1.00	1.00	1.13	3.25	-	-	4.60	20,000
SEB-1375	2.00	1.38	0.66	5.00	0.88	3.00	1.25	1.38	1.75	3.81	-	-	5.40	22,000
SEB-1750A	2.50	1.75	0.91	6.50	1.13	3.38	1.75	1.75	1.88	4.95	-	-	7.00	49,500
SEB-2000A	2.50	2.00	1.03	7.50	1.50	4.00	2.00	2.00	2.13	5.75	-	-	8.10	62,500
SEB-2500A	3.00	2.50	1.16	8.50	1.75	4.75	2.50	2.50	2.50	6.59	-	-	9.30	90,000
SEB-3000	3.00	3.00	1.28	9.50	2.00	5.25	2.75	2.75	2.75	7.50	-	-	10.60	105,500
SEB-3500	4.00	3.50	1.78	12.63	1.69	5.69	3.50	3.50	3.50	9.62	-	-	13.60	60,000
SEB-4000	4.50	4.00	2.03	14.88	1.94	6.44	3.88	3.88	4.00	11.50	-	-	16.20	75,000
SEB-5000	6.00	5.00	1.03	17.25	2.19	7.94	5.00	5.00	5.25	14.41	27.60	11.60	17.31	95,650
SEB-6000	7.00	6.00	1.28	20.00	2.63	9.38	5.50	6.00	6.25	17.50	22.50	15.00	19.00	187,500

## Recommended Torque Values

using MoS2 lubricant with .12 coefficient of friction

Thread Size	Torque	Thread Size	Torque
	ft•lbs		ft•lbs
.750-16	125	2.500-12	5,050
1.000-14	250	3.250-12	7,940
1.250-12	460	4.000-12	12,560
1.500-12	663	5.500-12	16,275
1.875-12	944	6.000-12	21,600
2.250-12	1,315		

### NOTES:

1. The load listed is max load in tension.
2. The pull load of the cylinder should be less than the listed load for the respective selected rod accessory.
3. Pivot pin is rated in shear.
4. All rod accessories must be torqued against rod shoulder.

Bore	Pin Ø	Thread Size KK	Thread Length A	Rod Clevis	Rod Eye	Eye Bracket	Rod Size	Thread Option	Rod Size	Thread Option
							EM02/EM20		EM30	
2.00	0.750	.750-16	1.13	FRC-0437	FRE-0750	SEB-0500	1.00	2	-	-
3.00	1.000	1.000-14	1.63	FRC-0750	FRE-1000	SEB-1000A	1.38	2	1.75	W
4.00	1.375	1.250-12	2.00	FRC-1000	FRE-1250	SEB-1375	1.75	2	2.00	W
5.00	1.750	1.500-12	2.25	FRC-1250	FRE-1500	SEB-1750A	2.00	2	2.50	W
6.00	2.000	1.875-12	3.00	FRC-1500	FRE-1875	SEB-2000A	2.50	2	3.00	W
7.00	2.500	2.250-12	3.50	FRC-1875	FRE-2250	SEB-2500A	3.00	2	3.50	W
8.00	3.000	2.500-12	3.50	FRC-2250	FRE-2500	SEB-3000	3.50	2	4.00	W
10.00	3.500	3.250-12	4.50	FRC-2500	FRE-3250	SEB-3500	5.50	W	5.00	W
12.00	4.000	4.000-12	5.50	FRC-3250	FRE-4000	SEB-4000	5.50	2	5.50	2
14.00	5.000	5.500-12	7.00	FRC-4000	FRE-5500	SEB-5000	7.00	2	7.00	2
16.00	6.000	6.000-12	9.00	FRC-5500	FRE-6000	SEB-6000	9.00	W	9.00	W

NOTES: Accessories selection chart is only a guide, select the accessories taking into consideration the pull load of the cylinder and the rated load of the accessory.

# Common Options

## Rod End Selection

In addition to selecting the correct bore, you must specify the appropriate rod size and rod end configuration for your application. Eight different inch rod end configurations are available. If a custom design is required, contact your local Eaton sales engineer, and we will build to your requirements. The table on page 39 gives maximum allowable push strokes at various operating

pressures for available rod diameters of Series EM cylinders. Rod ends on rigid mount cylinders should be supported. Longer strokes are allowable for pull only applications. Contact your local Eaton sales engineer for application assistance if necessary.

Code 4

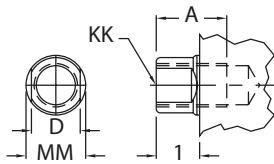

Code 2

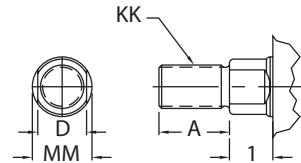

Code 5

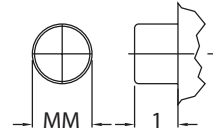

Code 1

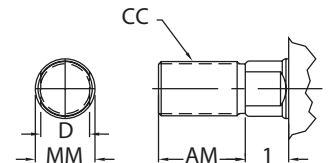

Code G

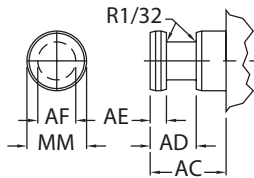

Code K

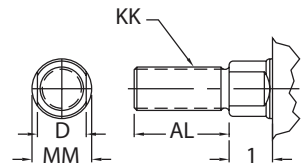

Code M

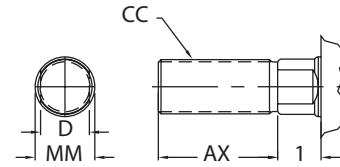

Code W<sup>3</sup>

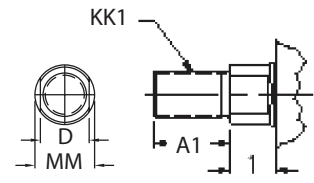

Rod Ø MM	A	AC	AD	AE	AF	AL	AM	AX	CC	D <sup>2</sup>	KK	A1	KK1
1	1.13	1.50	.94	.375	.688	1.56	1.50	1.94	.875-14	.875	750-16	-	-
1.375	1.63	1.75	1.06	.375	.875	2.19	2.00	2.75	1.250-12	1.125	1.000-14	-	-
1.75	2.00	1.75	1.31	.500	1.125	2.75	2.25	3.13	1.500-12	1.500	1.250-12	1.63	1.000-14
2	2.25	2.63	1.69	.625	1.375	3.13	3.00	4.13	1.750-12	1.688	1.500-12	2.00	1.250-12
2.5	3.00	3.25	1.94	.750	1.750	4.13	3.50	4.75	2.250-12	2.062	1.875-12	2.25	1.500-12
3	3.50	3.63	2.44	.875	2.250	4.75	3.50	5.50	2.750-12	2.625	2.250-12	3.00	1.875-12
3.5	3.50	4.38	2.69	1.000	2.500	5.00	4.50	6.38	3.250-12	3.000	2.500-12	3.50	2.250-12
4	4.00	4.50	2.69	1.000	3.000	5.63	4.50	6.56	3.750-12	-	3.000-12	3.50	2.500-12
4.5	4.50	4.50	2.69	1.000	3.000	6.38	5.00	7.31	3.750-12	-	3.250-12	-	-
5	5.00	5.38	3.19	1.500	3.875	7.00	5.00	7.56	4.750-12	-	3.500-12	4.50	3.250-12
5.5	5.50	6.25	3.94	1.875	4.375	7.75	6.75	9.56	5.250-12	-	4.000-12	4.50	3.250-12
7	7.00	6.50	4.06	2.000	5.750	10.00	7.00	10.50	6.500-12	-	5.500-12	-	-
8	8.00	6.50	4.06	2.000	6.500	11.25	8.00	12.00	7.500-12	-	6.000-12	-	-
9	9.00	6.75	4.13	2.000	7.250	12.50	9.00	13.50	8.500-12	-	6.500-12	9.00	6.000-12
10	10.00	7.25	4.63	2.375	8.000	14.00	10.00	15.13	9.500-12	-	7.250-12	-	-

**NOTE:**

1. Dimensions in inches.
2. Wrench flats for rods less than 4", larger rods will have 2 spanner holes 180° apart.
3. Thread option "W" should only be used for rod accessories. See accessory selection chart on page 27.

# Common Options

## Sealing Systems Up to 8" Bore

### Rod and Piston Seal Combinations

System Combinations	Rod Seal Code (position 21)	Piston Seal Code (position 22)	Temp. °F	Speed ft/sec	Application
N Normal Seals	N Normal	N Normal	-31 To 176	2.25	Normal, typical industrial
L Low Friction	L Low friction	N Normal	-31 To 176	15	Low friction servo
T High Temperature	T High temperature	T High temperature	-13 To 392	15	High temperature
H Load Holding	N Normal	H Load holding	-31 To 176	2.25	Load holding

### Rod Sealing

### Piston Sealing

	Hydraulic	Pneumatic	Hydraulic	Pneumatic	Fluid
<b>N - Normal</b>	Ultra urethane seal (1) PTFE seal with Nitrile energizer (1) Nitrile wiper (1) Phenolic wearbands	Nitrile U-cup seal (1) PTFE seal with Nitrile energizer (1) Nitrile wiper (1) Broze filled PTFE wearbands	PTFE seal with Nitrile energizer (1) Phenolic wearbands	Nitrile U-cup seal (2)	Mineral Oil, Petroleum Base Automotive trans mission fluid
<b>L - Low Friction</b>	PTFE seal with Nitrile energizer (2) Nitrile wiper (1) Phenolic wearbands	Nitrile U-cup seal (1) PTFE seal with Nitrile energizer (1) Nitrile wiper (1) Broze filled PTFE wearbands	PTFE seal with Nitrile energizer (1) Phenolic wearbands	Nitrile U-cup seal (2)	Mineral based oil Water in oil emulsions Petroleum based oil
<b>T - High Temp.<sup>1</sup></b>	PTFE seal with Viton energizer (2) Viton wiper (1) Phenolic wearbands	Viton U-cup seal (1) PTFE seal with Viton energizer (1) Viton wiper (1) Broze filled PTFE wearbands	PTFE seal with Viton energizer (2) Phenolic wearbands	Viton U-cup seal (2)	Petroleum based oil Mineral based oil Water under 150° F Phosphate esters
<b>H - Load Holding</b>	Ultra urethane seal (1) PTFE seal with Nitrile energizer (1) Nitrile wiper (1) Phenolic wearbands	NA	Nitrile capped-T seal Phenolic wearbands	NA	Mineral Oil, Petroleum Base Automotive trans mission fluid

<sup>1</sup>The high temperature seals can function upto 392°C but the wear band strength reduces accordingly.

### Rod Seals

Hydraulic - Normal



Hydraulic - Low Friction/  
High Temperature



Pneumatic - Normal/Low  
Friction/High Temperature



### Piston Seals

Hydraulic - Normal/Low Friction/  
High Temperature

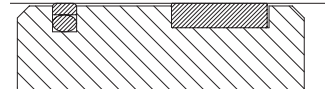

Hydraulic - Load Holding<sup>2</sup>

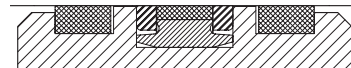

Pneumatic - Normal/Low  
Friction/High Temperature



<sup>2</sup>Load holding, capped-T seal configuration requires a longer piston than standard. This will increase the P and ZF dimensions listed on the dimensional drawings. Contact your Eaton representative with any questions and to find how this may effect your configuration.

# Common Options

## Sealing Systems for 10" and Above

### Rod and Piston Seal Combinations

System Combinations	Rod Seal Code (position 21)	Piston Seal Code (position 22)
N Normal Seals	N Normal	N Normal
L Low Friction	L Low Friction	N Normal
T High Temperature	T High Temperature	T High Temperature

Rod sealing	Piston Sealing	Temperature °F	Speed ft/sec	Seal Material	Fluid	Application
<b>N-N - Normal Sealing System</b>						
Polypak Buffer seal Wiper	Capped T-seal Wear bands	-31 To 176	2.25	Urethane PTFE Nitrile	Mineral Oil, Petroleum Base Automotive transmission fluid	Normal, Typical industrial
<b>L-L - Low Friction Sealing System</b>						
Buffer seal Wiper	Capped T-seal Wear bands	-31 To 176	15	PTFE Nitrile	Petroleum based oil Mineral based oil Water in oil emulsions	Low friction servo
<b>T-T - High Temperature Sealing System<sup>1</sup></b>						
Polypak Buffer seal Wiper	Capped T-seal Wear bands	-13 To 392	2.25	Viton PTFE Viton	Petroleum based oil Mineral based oil Water under 150° F Phosphate esters	High Temperature

<sup>1</sup> The high temperature seals can function upto 392°C but the wear band strength reduces accordingly.

### Rod Seal Configuration

N Seal Options

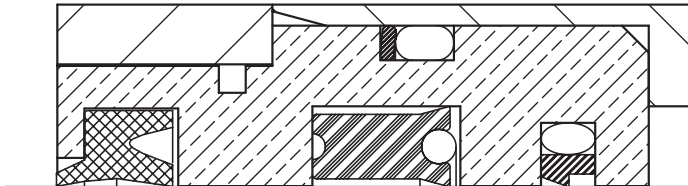

L and T Seal Option

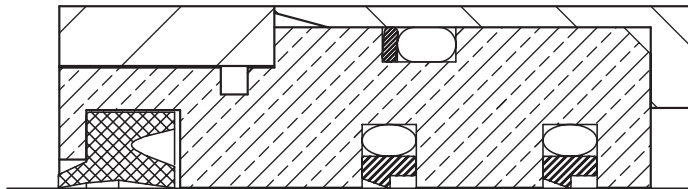

### Piston Seal Configuration-Hydraulic

N, L and T Seal Options

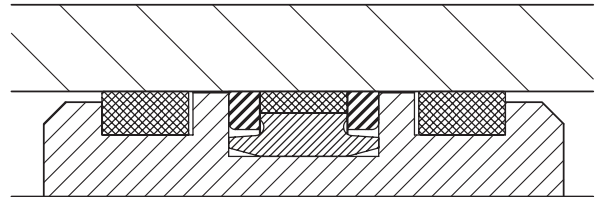

### Piston Seal Configuration-Pneumatic<sup>2</sup>

N, L and T Seal Options

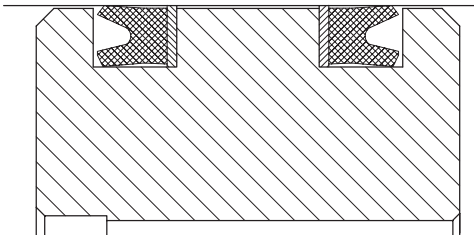

<sup>2</sup> U-Cop piston seals are standard for Pneumatic applications

# Common Options

## Port and Cushion Selection

### Port Code N & P

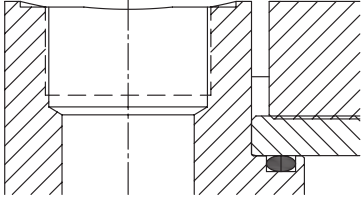

### Port Code S & U

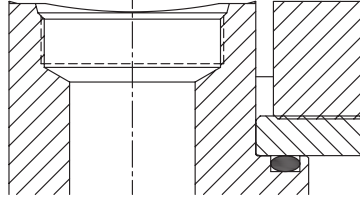

### Port Code G & H

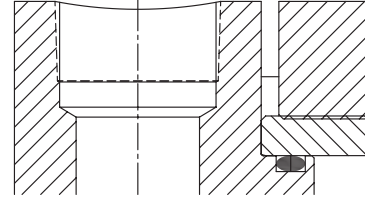

### Port Code F

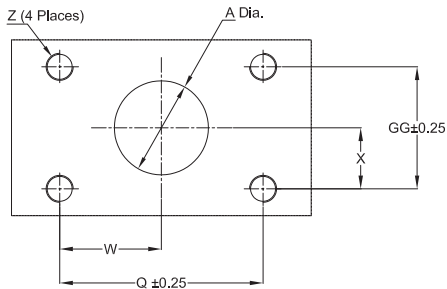

Flange Size	A	Q	W	X	Z	GG
1/2 (-8)	0.50	1.500	0.750	0.344	5/16-18	0.688
3/4 (-12)	0.75	1.875	0.938	0.438	3/8-16	0.875
1 (-16)	1.00	2.062	1.031	0.515	3/8-16	1.031
1-1/4 (-20)	1.25	2.312	1.156	0.594	7/16-14	1.188
1-1/2 (-24)	1.50	2.750	1.375	0.703	1/2-13	1.406
2 (-32)	2.00	3.062	1.531	0.844	1/2-13	1.688
2-1/2 (-40)	2.50	3.500	1.750	1.000	1/2-13	2.000
3 (48)	3.00	4.188	2.094	1.217	5/8-11	2.438

### EM20/EM02

Bore Ø in.	Port Code N NPTF* Pipe		S SAE J1926 UN Thread O-Ring/Thread Size		F SAE 518 Code 61 Flange	G ISO 228-1 BSPP*	
	Standard	P Oversize	Standard	U Oversize		Standard	H Oversize
2.00	1/2	3/4	#6	#8	-	1/2	-
3.00	1/2	3/4	#8	#12	-	1/2	3/4
4.00	3/4	1	#10	#12	1/2 (-8)	1/2	3/4
5.00	3/4	1	#12	#16	3/4 (-12)	1/2	3/4
6.00	1	1-1/4	#16	#20	1 (-16)	3/4	1
7.00	1-1/4	1-1/2	#16	#20	1-1/4 (-20)	1	1-1/4
8.00	1-1/2	2	#24	#32	1-1/2 (-24)	1-1/4	1-1/2
10.00	2	-	#32	-	2 (-32)	2	-
12.00	2-1/2	-	#32	-	2-1/2 (-40)	2-1/2	-
14.00	2-1/2	-	#32	-	2-1/2 (-40)	2-1/2	-
16.00	3	-	#32	-	3 (-48)	3	-

### EM30

Bore Ø in.	Port Code N NPTF* Pipe		S SAE J1926 UN Thread O-Ring/Thread Size		F SAE 518 Code 61 Flange	G ISO 228-1 BSPP*	
	Standard	P Oversize	Standard	U Oversize		Standard	H Oversize
3.00	1/2	3/4	#6	#8	-	1/2	3/4
4.00	1/2	3/4	#10	#12	1/2 (-8)	1/2	3/4
5.00	3/4	1	#12	#16	3/4 (-12)	1/2	3/4
6.00	1	1-1/4	#16	#20	1 (-16)	3/4	1
7.00	1	1-1/4	#16	#20	1-1/4 (-20)	1	1-1/4
8.00	1-1/2	2	#20	#24	1-1/2 (-24)	1-1/4	1-1/2
10.00	2	-	#32	-	2 (-32)	2	-
12.00	2-1/2	-	#32	-	2-1/2 (-40)	2-1/2	-
14.00	2-1/2	-	#32	-	2-1/2 (-40)	2-1/2	-
16.00	3	-	#32	-	3 (-48)	3	-

\*NPTF and BSPP ports are not recommended for maximum reliability on new applications.



# Common Options

## Port and Cushion Selection

Port and cushion locations are identified by viewing the cylinder from the head end (or from the mounting end of double rod cylinder). The location numbers are shown to the right. Certain port and cushion locations cannot be specified with some mounting styles. The table below indicates which of the head and cap port location are available for EM Series all mounting style.

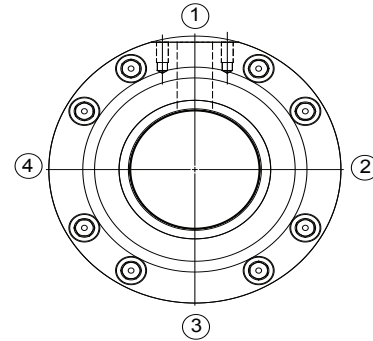

### Port Location Availability Chart

Mounting Style Code	Description	Head Location				Cap Location			
		1	2	3	4	1	2	3	4
AS	Side Lug	A	A	<b>N</b>	A	A	A	<b>N</b>	A
GS	Head Rectangular	A	A	A	A	A	A	A	A
CM	Cap Clevis	A	A	A	A	A	A	A	A
CS	Spherical Bearing	A	A	A	A	A	A	A	A
PS	Cap Rectangular	A	A	A	A	A	A	A	A
TS	Intermediate Trunnion	A	A	A	A	A	A	A	A
US	Head Trunnion	A	<b>N</b>	A	<b>N</b>	A	A	A	A
FS	Head Circular Flange	A	A	A	A	A	A	A	A
KS	No Mount	A	A	A	A	A	A	A	A
KS	Double Rod Side Lug	A	A	<b>N</b>	A				
AD	Double Rod Rectangular	A	A	A	A				
GD	Double Rod Intermediate Trunnion	A	A	A	A				
TD	Double Rod No Mount	A	A	A	A				
KD	Double Rod No Mount	A	A	A	A				

A-Available

**N**-Not available

### Cushion Availability Chart\*

Mounting Style Code	Description	Head Location				Cap Location			
		1	2	3	4	1	2	3	4
AS	Side Lug	A	A	<b>N</b>	A	A	A	<b>N</b>	A
GS	Head Rectangular	A	<b>N</b>	A	<b>N</b>	A	A	A	A
CM	Cap Clevis	A	A	A	A	A	A	A	A
CS	Spherical Bearing	A	A	A	A	A	A	A	A
PS	Cap Rectangular	A	A	A	A	A	<b>N</b>	A	<b>N</b>
TS	Intermediate Trunnion	A	A	A	A	A	A	A	A
US	Head Trunnion	A	<b>N</b>	A	<b>N</b>	A	A	A	A
FS	Head Circular Flange	A	A	A	A	A	A	A	A
KS	No Mount	A	A	A	A	A	A	A	A
AD	Double Rod Side Lug	A	A	<b>N</b>	A				
GD	Double Rod Rectangular	A	<b>N</b>	A	<b>N</b>				
TD	Double Rod Intermediate Trunnion	A	A	A	A				
KD	Double Rod No Mount	A	A	A	A				

A-Available

**N**-Not available

\* Cushion option is not available for 2.00 Bore on rod end for all mounts.

#### NOTE:

Certain port and cushion locations cannot be specified with some mounting styles. The table above indicates which of the head and cap port location are available for each series EM30/EM20/EM02 mounting style

1) Standard Cushion adjustment position is Port position +1, e.g., if Port is at 3, then cushion is at 4

2) If the above calculated Cushion position is not available per the "Cushion availability chart" then it will be the next available location (excluding port location)

# Common Options

## Seal Kit Part Numbers

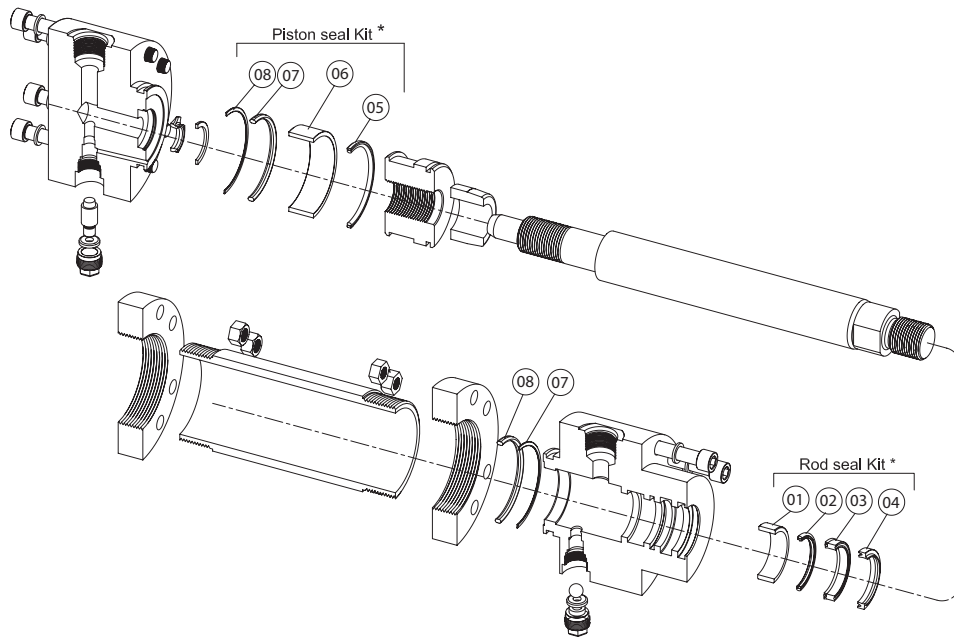

### 3000 psi piston seal kit

Bore	Normal/Low friction	High Temp.	Load holding
3.00	6633NEAF	6643TEAF	6633HEAF
4.00	6633NEAH	6643TEAH	6633HEAH
5.00	6633NEAK	6643TEAK	6633HEAK
6.00	6633NEAL	6643TEAL	6633HEAL
7.00	6633NEAM	6643TEAM	6633HEAM
8.00	6633NEAN	6643TEAN	6633HEAN

### 2000 psi piston seal kit

Bore	Normal/Low friction	High Temp.	Load holding
2.00	6633NEBD	6643TEBD	6633HEBD
3.00	6633NEBF	6643TEBF	6633HEBF
4.00	6633NEBH	6643TEBH	6633HEBH
5.00	6633NEBK	6643TEBK	6633HEBK
6.00	6633NEBL	6643TEBL	6633HEBL
7.00	6633NEBM	6643TEBM	6633HEBM
8.00	6633NEBN	6643TEBN	6633HEBN

### 250 psi piston seal kit

Bore	Normal/Low friction	High Temp.	Load holding
2.00	6633NECD	6643TECD	6633HECD
3.00	6633NECF	6643TECF	6633HECF
4.00	6633NECH	6643TECH	6633HECH
5.00	6633NECK	6643TECK	6633HECK
6.00	6633NECL	6643TECL	6633HECL
7.00	6633NECM	6643TECM	6633HECM
8.00	6633NECN	6643TECN	6633HECN

#### Note:

- Piston seal kit contains 1 set of piston seal , wear bands, 2 sets of body O-ring and backup.
- Rod seal kit contains wiper , buffer seal and a primary rod seal along with wear bands
- No of wear bands on piston / rod will change based on bore/rod and pressure combinations
- For above 10" bores consult Eaton's Customer service

### Rod seal Kit

Bore	Rod	Normal	Low friction	High Temp.
3.00	1.75	6633N-EAFL	6633L-EAFL	6643T-EAFL
3.00	2.00	6633N-EAFM	6633L-EAFM	6643T-EAFM
4.00	2.00	6633N-EAHM	6633L-EAHM	6643T-EAHM
4.00	2.50	6633N-EAHP	6633L-EAHP	6643T-EAHP
5.00	2.50	6633N-EAKP	6633L-EAKP	6643T-EAKP
5.00	3.50	6633N-EAKV	6633L-EAKV	6643T-EAKV
6.00	3.00	6633N-EALU	6633L-EALU	6643T-EALU
6.00	4.00	6633N-EALW	6633L-EALW	6643T-EALW
7.00	3.50	6633N-EAMV	6633L-EAMV	6643T-EAMV
7.00	5.00	6633N-EAMZ	6633L-EAMZ	6643T-EAMZ
8.00	4.00	6633N-EANW	6633L-EANW	6643T-EANW
8.00	5.50	6633N-EAN1	6633L-EAN1	6643T-EAN1

### 250 psi and 2000 psi rod seal kit

Bore	Rod	Normal	Low friction	High Temp.
2.00	1.00	6633N-EBDE	6633L-EBDE	6643T-EBDE
2.00	1.38	6633N-EBDH	6633L-EBDH	6643T-EBDH
3.00	1.38	6633N-EBFH	6633L-EBFH	6643T-EBFH
3.00	2.00	6633N-EBFM	6633L-EBFM	6643T-EBFM
4.00	1.75	6633N-EBHL	6633L-EBHL	6643T-EBHL
4.00	2.50	6633N-EBHP	6633L-EBHP	6643T-EBHP
5.00	2.00	6633N-EBKM	6633L-EBKM	6643T-EBKM
5.00	3.50	6633N-EBKV	6633L-EBKV	6643T-EBKV
6.00	2.50	6633N-EBLP	6633L-EBLP	6643T-EBLP
6.00	4.00	6633N-EBLW	6633L-EBLW	6643T-EBLW
7.00	3.00	6633N-EBMU	6633L-EBMU	6643T-EBMU
7.00	5.00	6633N-EBMZ	6633L-EBMZ	6643T-EBMZ
8.00	3.50	6633N-EBNV	6633L-EBNV	6643T-EBNV
8.00	5.50	6633N-EBN1	6633L-EBN1	6643T-EBN1

# Common Options

## Special Rod & Other Options

### Special Rod Ends

Modifications of standard rod ends or completely special rod end styles are available to meet unique rod end connection requirements.

### Rod Boots

A rod boot surrounds the piston rod with an external, expandable cover to protect the rod surface from external contamination. Requires additional rod length which is determined by the cylinder stroke.

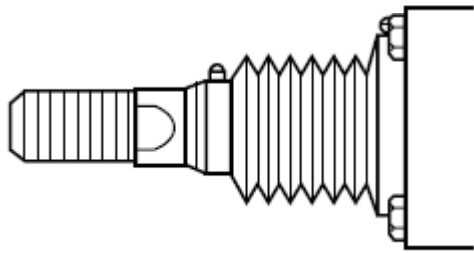

### Metallic Rod Scraper

A metallic rod scraper provides increased rod seal life by removing abrasive contamination from the rod in severe applications.

### Special Rod Materials

Piston rods in 300 and 400 series, 17-4 PH and others are available for those applications requiring increased corrosion resistance.

Nitrotec® coated rods are an option for rods requiring superior corrosion resistance than that found with chrome plating but more affordable than solid stainless rods. The Nitrotec® process does not have micro cracks found with Hard Chrome plating. The process is also more environmentally friendly than standard chrome plating because of all the chemicals associated in the chrome process.

### Extra Heavy Chrome Tubes and Rods

Added wear and corrosion resistance are available by specifying Extra Heavy Chrome (.002" to .003" thick).

### Special Coating and Painting

Cylinders can be prepared with a primer coat, epoxy, lacquer or enamel paint finish coatings to customer specifications. Synergistic, Nitro carburizing and other material treatments are also available for special applications.

### Plating

Electro less Nickel, Cadmium and other plating finishes are available for corrosive, wash down, pharmaceutical and other applications.

### Special Materials

Bronze rod cartridges, brass, aluminum and composite tubing, complete stainless steel cylinders or other special materials are available to meet most unique material requirements.

## Other Options

### Gland Drain Option

Gland drains are primarily used for long stroke cylinders (over 30 inches) and when extended speed exceeds retract speed. The gland drain is used to return any accumulated fluid, between the rod seal and wiper to tank. This is used in servo applications, for ultralow leakage requirements, or for remote visual monitoring seal leakage for preventive maintenance purposes.

### Air Bleed Option

Usually cylinders will bleed themselves of air when ports are vertical, on top. Bleed ports are often desirable to remove entrapped air, when the ports are on the bottom. High performance and high speed or heavy load applications are a few examples where air bleeds desirable.

### Special Cylinders

For special cylinder out of this catalog range, Eaton's engineering and design team is ready to produce special designs to meet customer's requirements. Contact your Eaton sales representative for any special requirements like special mounting, special seals, special bore diameter, special piston rod diameter, special pressure requirements etc.

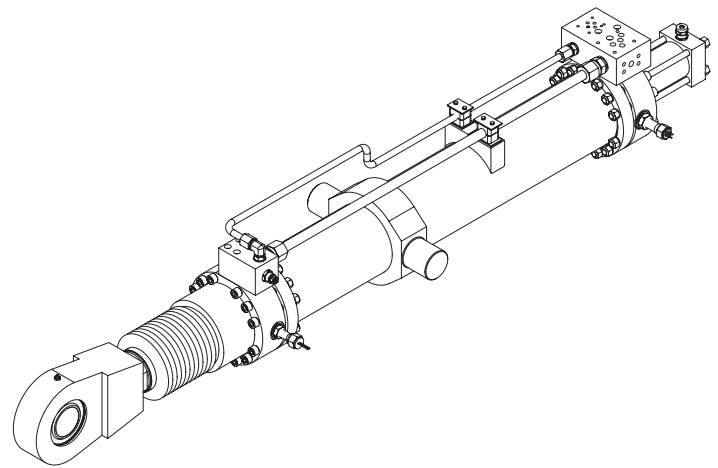

# Application/Engineering Data

## Stop Tube

### Stop Tube Design

As the stroke length of a cylinder increases, the resultant bearing loads on the piston rod becomes greater, To keep these bearing loads from exceeding design limitations and to obtain optimum life from a cylinder, stop tubes are recommended.

To determine if stop tube is required and the length of top tube needed, use the following procedure:

Determine the value of D with the piston rod in the fully extended position based on rod condition. If the value of D is under 40 inches, no stop tube is needed. If D is greater than 40 inches, one inches of stop tube is recommended for each 10 inch, or fraction thereof, beyond 40 inches.

**Note:** When specifying stroke and stop tube lengths, please include networking stroke plus stop tube length.

#### Rigid Mounts

$D=4S$   
Unsupported Rod End

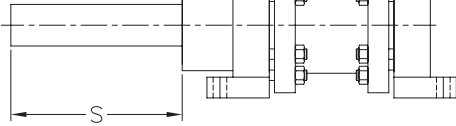

$D=S$   
Supported Rod End

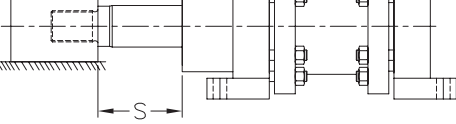

$D=0.5S$   
Firmly Guided Rod End

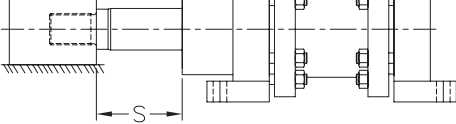

#### Swivel Mounts

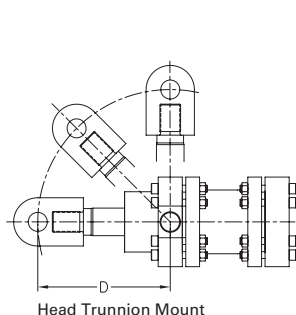
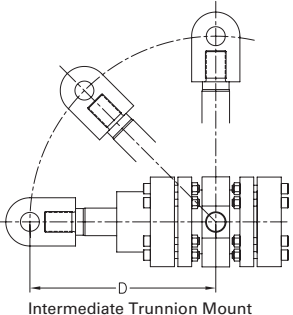
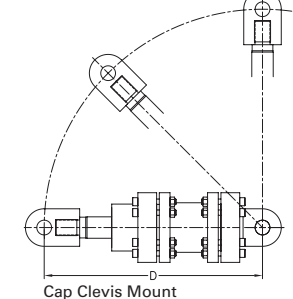

As illustrated below stop tube is placed between piston and cylinder head to restrict the additional strength and side support for the extended rod.

Three typical stop tube designs are illustrated below:

#### Design A ( Stop Tube)

Used for cylinders non-cushioned on the rod

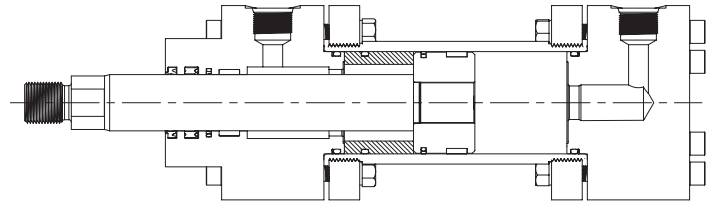

#### Design B (Stop spacer)

Used for cushioned cylinders

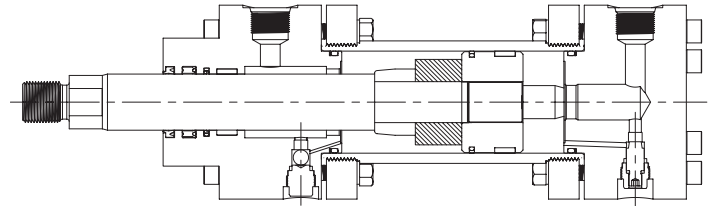

#### Design C (Double piston with spacer)

The best choice for a cylinder with an exceptionally long stop tube requirement. Note that piston's effective bearing area is doubled, in addition to gaining the normal increased minimum distance between bearing points

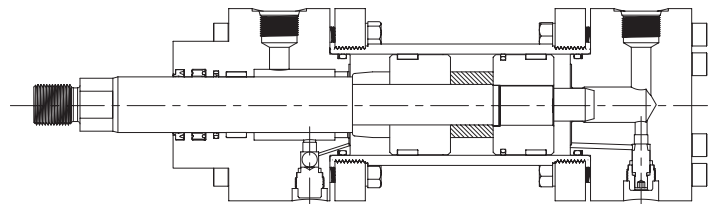

## Application/Engineering Data

### Proximity Switches

Proximity switches for series EM cylinder are inductive type switches with sensing probe that “looks” at the cushion collar or button to provide extended or retracted indication. Since the probe is inside the cylinder, Harsh external environments don’t affect sensing. The 2-wire circuit will operate on AC or DC and works as reliably as a programmable controller.

Proximity switches will meet UL requirements for 3000-psi (210 bar) hydraulic cylinder. Switch will allow 304° rotations. Short

Circuit protection is standard feature on proximity switch. SCP protects the switch from shorts in load or line. Upon sensing short condition, the switch assumes a non-conducting mode. The fault condition must be removed and power turned off in order to reset the switch. This feature prevents unintended automatic restarts. The switch indicated when it is in SCP mode by flashing both leads.

Torque ¼-20 mounting screws to 15 ft-lb (20 Nm)

#### Series PS 200 2-wire AC / DC Proximity Switch Specifications:

Pressure	3000 PSI
Sensing Range	0.08 in ± 10 %
Sensing distance from End of stroke	0.25” - 0.38” stroke to go
Operating temperature range	-13° to +158° F
Repeatability	0.001 in
Switching differential	≤ 15%
Supply Voltage	20 - 250 V AC / DC
Voltage drop	≤ 6 V
Load Current capacity @ 25° C	5-400 mA
Inrush current	≤ 3A (t ≤ 20ms)
Indicating LED’s (Standard)	1 lit: Power on non-conducting 2 lit: Target present (Both flashing = SCP mode)

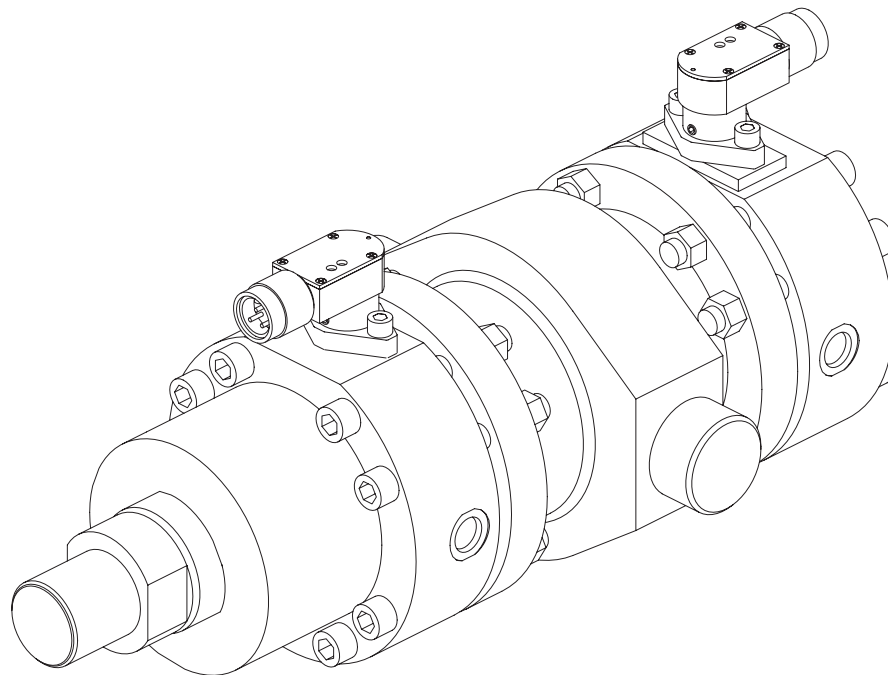

# Application/Engineering Data

## Transducer Options

A complete line of precision cylinder position sensing and feedback devices are available. These packaged cylinder systems can handle virtually any application requiring feedback throughout

the cylinder stroke —pneumatic or hydraulic, large or small bore, long or short strokes, with or without velocity monitoring — with resolutions of  $\pm 0.001$ " or better.

### Thread-In Style Transducers

Industry standard transducer type for industrial cylinder applications. Cylinders can be manufactured prepared for transducer or with transducer already installed.

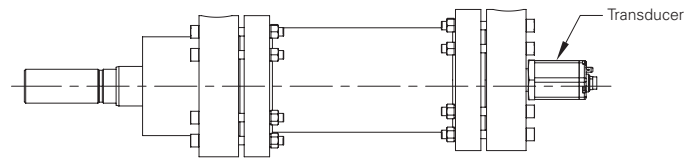

Two different protective cover options are available for rugged environments protect the electronics.

### Transducer Cover

Rugged aluminum casting cover protects the transducer from minor wear and tear, yet is easily removable to service the transducer.

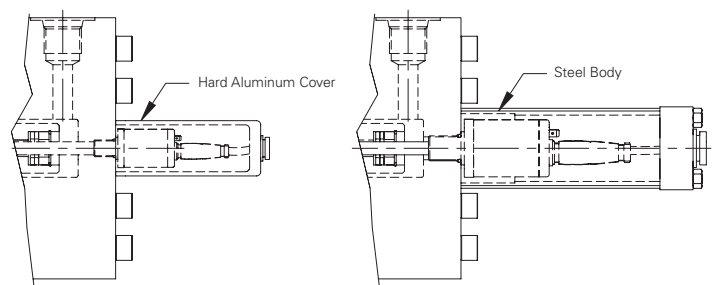

### False Stage Cover

Transducer is protected by a tie-rod cylinder body and end cap for the best protection short of the encapsulated HLT II design. Utilize this design when you need heavy duty protection for the transducer, yet need output options not available in the HLT II.

### False Stage Cover Mount

Heavy duty false stage covers that are suitable for rear mounts (clevis, spherical bearing, etc.) are available. Utilize this design when you need heavy duty protection for the transducer in a rear mount cylinder, yet need output options not available in the HLT II.

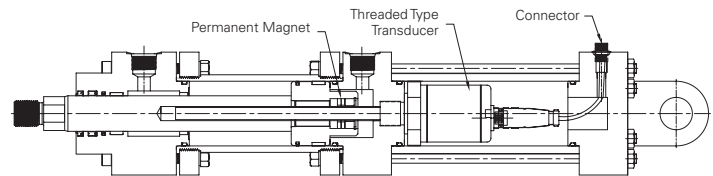

### Eaton HLT II

The Eaton HLT II linear displacement transducers are precise, durable, cost-effective measurement devices. Well protected within the core of the cylinder, the HLT II not only measures the position of the moving elements of an actuation system, but also remains untouched, and unaffected by even the harshest elements. HLT II also is an ideal choice, with it's compact design, when overall cylinder length is a concern. The innovative encapsulated design and engineering along with the rugged construction of Eaton HLT II transducers guarantee the best reliability, precision and durability in even the toughest industrial environment.

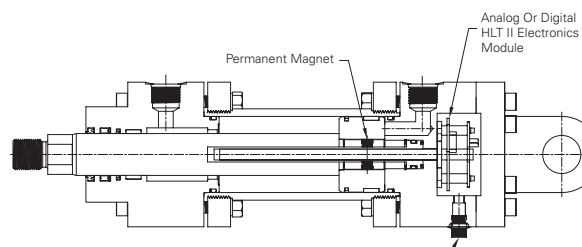

### Custom Transducers

Eaton has been an industry pioneer incorporating positioning systems into industrial cylinders, and can find design system for any application. If a specific type of system is required and not listed here, Eaton can create custom cylinders incorporating your needs.

# Application/Engineering Data

## Buckling Chart

### Buckling Chart:

Maximum allowable length 'L' in full extend condition. In push applications, a cylinder acts as a loaded column. To use the table below, first go to the section for your mounting style. Then locate the column with pressure which is closest to, but not below, your application's operating pressure. The intersection of

operating pressure and the bore/rod size represents the maximum allowable length 'L' in full extend condition. This maximum length is based on column loading analysis only and does not consider side loading, stop tube requirements, or other cylinder stroke limiter. For pressures above 3000 psi, consult your local Eaton representative.

BORE ø in	ROD ø in	Rigid Mount Styles AS, GS, PS							Swivel Mount Styles CM, CS, TS						
		3000 psi	2000 psi	1500 psi	1000 psi	750 psi	500 psi	250 psi	3000 psi	2000 psi	1500 psi	1000 psi	750 psi	500 psi	250 psi
2.00	1.00	30	36	42	51	59	73	103	21	26	30	36	42	51	73
	1.38	56	69	79	97	112	137	194	40	49	56	69	79	97	137
3.00	1.38	37	46	53	65	75	92	130	26	32	37	46	53	65	92
	2.00	79	97	112	137	158	194	274	56	69	79	97	112	137	194
4.00	1.75	61	74	86	105	121	148	210	43	52	61	74	86	105	148
	2.50	93	114	131	161	186	227	321	66	80	93	114	131	161	227
5.00	2.00	45	58	67	82	95	116	165	32	41	47	58	67	82	116
	2.50	74	91	105	129	148	182	257	52	64	74	91	105	129	182
6.00	3.50	145	178	206	252	291	356	504	103	126	145	178	206	252	356
	2.50	60	76	87	107	124	151	214	43	54	62	76	87	107	151
7.00	3.00	89	109	126	154	178	218	308	63	77	89	109	126	154	218
	4.00	158	194	224	274	317	388	548	112	137	158	194	224	274	388
8.00	3.50	76	93	108	132	153	187	264	53	66	76	93	108	132	187
	5.00	212	260	300	367	424	519	735	150	184	212	260	300	367	519
9.00	4.00	90	111	129	157	182	223	315	64	79	91	111	129	157	223
	5.50	224	275	317	389	449	550	778	159	194	224	275	317	389	550
10.00	4.00	90	116	134	165	190	233	329	64	82	95	116	134	165	233
	5.50	180	220	254	311	359	440	622	127	156	180	220	254	311	440
11.00	7.00	291	356	411	504	582	713	1008	206	252	291	356	411	504	713
	5.50	141	183	212	259	299	367	518	100	130	150	183	212	259	367
12.00	7.00	225	297	343	420	485	594	840	159	210	242	297	343	420	594
	8.00	316	338	448	548	633	766	1097	224	274	317	388	488	548	776
13.00	7.00	104	247	294	360	416	509	720	73	174	208	254	294	360	509
	9.00	341	421	486	595	687	841	1190	241	297	344	421	486	595	841
14.00	9.00	265	368	425	521	601	736	1041	187	260	301	368	425	521	736
	10.00	364	454	525	643	742	909	1285	257	321	371	454	525	643	909

### End conditions for above chart:

Mount	Condition
AM, GM, PM	Fixed-Guided
CM, CS, TM	Pin-Pin

### Calculation according to Euler

$$P = \left[ \frac{C \pi^2 EI}{FL^2} \right] \text{ if } \frac{L}{k} > \left[ \frac{2C \pi^2 E}{S_y} \right]^{0.5}$$

### Calculation according to Jb Johnson

$$P = \frac{AS_y}{F} \left[ 1 - \frac{S_y L^2}{4C \pi^2 E k^2} \right] \text{ if } \frac{L}{k} \leq \left[ \frac{2C \pi^2 E}{S_y} \right]^{0.5}$$

- F** Safety factor, 3.5
- P** Critical load, Lb
- E** Modulus of elasticity, 30000000 psi
- L** Length, in
- I** Moment of inertia, in<sup>4</sup>
- C** End condition  
Fixed-Guide, 2  
Fixed-Fixed, 4  
Pin-Pin, 1
- A** Rod area, in<sup>2</sup>
- k** Radius of gyration, in

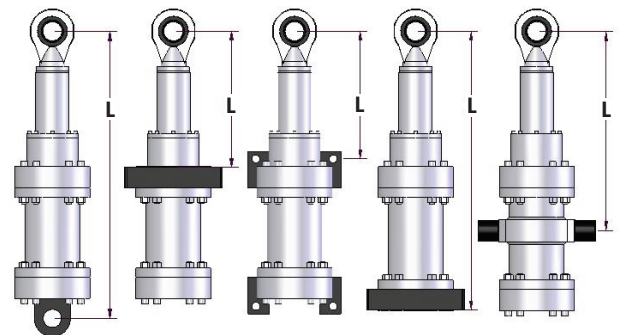

**Notes:**



# Eaton's Application Data Sheet

Customer Name:			
Customer P/N ---	Rev ---	Machine ---	Function ---
Contact	Ph	Fax	e-mail
<b>Cylinder Description</b>			
Series	Mtg Style :	Bore	Stroke
Cushions: None		Rod End Pos:	Blind End Pos:
Weight Connected to Rod (lbs):			
<b>How is Cylinder Mounted</b>			
Horizontal	Vertical	Rod Up	Rod Down
		Angle	Degrees from Vertical
Rod End Connection	Firmly Guided	Supported	Unsupported
Know Side Load (lbs)			
<b>How is Cylinder Used</b>			
Operating Fluid: Petroleum Oil		Fluid Temp @ Cylinder:	
Pressure Setting Extend:		Pressure Setting Retract:	
Stop Internal Ext	Stop Internal Ret	Stop External Ext	Stop External Ret
Force Ext lb <sub>f</sub>	Force Ret lb <sub>f</sub>	Velocity Ext:	Velocity Ret:
Cycle Rate:	Cycle Life of Cylinder:	Cycle Life Seals:	
<b>Environmental Conditions</b>			
Standard Factory	Very Dirty	Outdoors	Other:
Application Sketch		Special Requirements	
Prepared By	Date	Reviewed By	Date

**Notes:**

**Notes:**

**Eaton**  
Hydraulics Group USA  
14615 Lone Oak Road  
Eden Prairie, MN 55344  
USA  
Tel: 952-937-9800  
Fax: 952-294-7722  
[www.eaton.com/hydraulics](http://www.eaton.com/hydraulics)

**Eaton**  
Hydraulics Group Europe  
Route de la Longeraie 7  
1110 Morges  
Switzerland  
Tel: +41 (0) 21 811 4600  
Fax: +41 (0) 21 811 4601

**Eaton**  
Hydraulics Group Asia Pacific  
Eaton Building  
4th Floor, No. 3 Lane 280 Linhong Rd.  
Changning District  
Shanghai 200335  
China  
Tel: (+86 21) 5200 0099  
Fax: (+86 21) 5200 0400